



UNIVERSITÉ DE  
MONTPELLIER



POLYTECH<sup>®</sup>  
MONTPELLIER

2023-2024



STUDENTS PROJECTS CATALOGUE





**TRANSVERSAL PROJECTS**



**EGC**



**GBA**



**MAT**



**IG**



**MI**



**DO**



**MSI**



**SE**

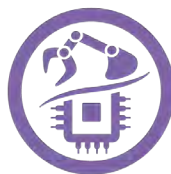

**MEA**



**STE**



# Immersive drone piloting

CoHoMa Mission



Achille  
BERNAT

Achille BERNAT IG Romain FREZIER IG Nuihau TEENA IG

Academic Supervisor : Thomas Godel



Romain  
FREZIER



Nuihau  
TEENA



## Objective / Motivation :

The French Army is looking to equip some troops with robots to enhance operational efficiency and team safety. Combining human and robotic capabilities will enhance overall skills and performance in the field. As part of the CoHoMa 3 mission, drones are mobilized to locate, identify and neutralize targets. The idea is to enhance the user experience by making the drone operating immersive, and adding navigation in 3D cartography through a virtual or augmented reality headset.

## Results :

The VR headset application is developed using Unity. A UI is added as an overlay to the video feedback and to the 3D environment. This interface can be used to display a list of drones, or to tell a drone which direction it should take. Information is sent by ROS, already at the heart of the system in place for the CoHoMa 2 mission. The application is connected to ROS via the same network and communicates with it via messages. The scan of the environment is transformed into a 3D object and transmitted to the application.

## Keywords :

Unity, 3D, ROS, Python, Virtual Reality



Visualization of scanned virtual environment inside the headset

Contact(s) : [achille.bernat@etu.umontpellier.fr](mailto:achille.bernat@etu.umontpellier.fr) [romain.frezier@etu.umontpellier.fr](mailto:romain.frezier@etu.umontpellier.fr) [nuihau.teena@etu.umontpellier.fr](mailto:nuihau.teena@etu.umontpellier.fr)





# Improved dissemination of customer requirements and facilitation of their application



Noémie  
BLAZQUEZ

AdVini Group

Noémie BLAZQUEZ GBA

Academic Supervisor : Marylène Demoulin



ADVINI  
DES VIGNOBLES & DES HOMMES

## Objective / Motivation :

The objective of this project is to participate in the continuous quality improvement of the Advini group, which is a French company specializing in wine. Throughout the process, from production to distribution, numerous rigorous procedures are put in place to guarantee optimal quality. Quality is an essential element to guarantee the safety and satisfaction of various customers.

## Results :

During this project, I was in charge of several missions. First of all, I read and analyzed the specifications of the France and Export clients of the Advini group. Following the analysis of each of the specifications, I developed an Excel summary file of the applied requirements intended for the Quality managers of the production sites. Moreover, I was also in charge of updating an Excel file listing the regulations by country as part of regulatory monitoring.

## Keywords :

AdVini, Wine, Regulations, Specification, Regulatory Monitoring



Mapping of AdVini group certifications

Contact(s) : noemie.blazquez@etu.umontpellier.fr





# Ecotrophelia France 2024 competition

Aro'Marins - salt substitute



Eloïse  
DELINCOURT

Eloïse DELINCOURT *GBA* Aléna RAFFAILLAC *GBA* Coline NAZET *GBA*

Academic Supervisor : Dominique Chevalier-Lucia, Sylvie Marchesseau, Céline Breton, Maëva Hostachy



# ARO MARINS

## Objective / Motivation :

We are the Aro'Marins, a group of 5 engineering students from Polytech Montpellier. This year, we're taking part in Ecotrophelia France 2024, a food innovation and eco-design competition. Looking for new flavors, our challenge was to find an innovative way to add value to fish co-products, such as skins, bones, tails and fins, which are not used in human food even though they have nutritional potential (minerals and omega-3). That's why, we've created a salt substitute, based on wild fish co-products and a blend of organic spices and herbs.

## Results :

With fish co-products and a drying technology, we've created a product game, Spisea, with 3 flavors: Special Meats, Fish, and Grilled Vegetables and Salads. Our raw materials come from local suppliers in the Occitanie region to promote short supply chains and our final product is packaged in a refillable glass mill using recyclable eco-refills. Through this start-up project, we were able to approach all aspects of project development (R&D, marketing, industrialization, etc.).

## Keywords :

Start-up project, Food innovation, Eco-design, Salt substitute, Fish co-products, Minerals, Omega-3.



Raw material



Finished product from the Spisea range

Contact(s) : [eloise.delincourt@etu.umontpellier.fr](mailto:eloise.delincourt@etu.umontpellier.fr) [alena.raffailac@etu.umontpellier.fr](mailto:alena.raffailac@etu.umontpellier.fr) [coline.nazet@etu.umontpellier.fr](mailto:coline.nazet@etu.umontpellier.fr)



# Debryde: producing beer through collaboration between Polytech and the University of Sherbrooke



Emma  
GONZALEZ

Collaboration in order to develop a innovative beer starting at a laboratory scale in Montpellier and moving on to the industrial scale at Sherbrooke

Emma GONZALEZ *GBA* Andriantelina Fitiavana ROBINSON *GBA* James Vico B ANTENOR *GBA*

Academic Supervisor : Charles Cunault - Alexandre Colas De La Noue - Caroline Strub



Andriantelina Fitiavana  
ROBINSON



James Vico B  
ANTENOR



## Objective / Motivation :

The aim of the project is to develop a recipe through trans-Atlantic collaboration. The students involved in the project chose the type of beer to be made, and therefore the associated raw materials and processes. We had to define and conduct an experiment. The quality part of the project consisted in drawing up procedure sheets and operating modes for all the steps involved, in order to facilitate the transfer of scale. We also had to choose which quality analyses to carry out, and monitor them throughout the process using a standardized tracking file.

## Results :

Within the given time, the recipe was tested with four different combinations in order to reach the specifications. And then they were tested by sensory analysis, generally speaking testers really like the beer, but missed some fruits aromas. The final choice of raw materials will be made after analysis of the last brews produced.

## Keywords :

Beer, quality analysis, sensory analysis, collaboration



Four different recipes brewed in the polytech Montpellier laboratory



Sensory analysis session

Contact(s) : emma.gonzalez@etu.umontpellier.fr fitiavanaandriantelina@gmail.com james.antenor@etu.umontpellier.fr



## Prospective study

### Formulation and Characterization of Concentrated Emulsions of Turpentine Essential Oil



Marianne  
HONORÉ-CARLIER

Marianne HONORÉ-CARLIER GBA

Academic Supervisor : Pascale Chalier



L'ACCENT  
DERMO / MAQUILLAGE

#### Objective / Motivation :

This confidential study, conducted with the company L'ACCENT, aimed to find the best formulation for an emulsion containing turpentine essential oil from Cevennes pine resin. It's aim is to be diluted for therapeutic use in repeated showers. Two main factors were examined: emulsifier quantity and essential oil amount. Various parameters were assessed for homogeneity and stability, including viscosity, particle size, PET affinity, and storage stability at different temperatures.

#### Results :

Initially, the study found that higher emulsifier amounts increased viscosity, while higher essential oil amounts decreased it. Stability analyses demonstrated that higher temperatures intensified emulsion destabilization. As both emulsifier and essential oil quantities increased, the emulsions became more unstable, leading to larger droplet sizes exceeding 1  $\mu\text{m}$ . Overall, the project culminated in selecting the optimal formulation.

#### Keywords :

Emulsion, turpentine essential oil, granulometry, stability, viscosity.



Pine tree (Source : [www.jardiland.com](http://www.jardiland.com))

Contact(s) : [marianne.honore-carlier@etu.umontpellier.fr](mailto:marianne.honore-carlier@etu.umontpellier.fr)



# Prospective study: Formulation, physicochemical characterization and monitoring of the colloidal stability of a mascara



Confidential

Laureen  
JOACHIM

Laureen JOACHIM *GBA*

Academic Supervisor : Pascale CHALIER / Michael NIGEN



L'ACCENT  
DERMO / MAQUILLAGE

## Objective / Motivation :

This research innovates mascara formulation by focusing on colophony, a natural resin, for its film-forming and stabilizing qualities. In collaboration with L' Accent, the project explores integrating colophony into mascara formulations. Trials evaluate its effectiveness, analyzing characteristics like droplet size, viscosity, stability, drying time, dry matter percentage, and lash curvature angle for optimization. The results contribute to creating sustainable and environmentally friendly cosmetic solutions.

## Results :

The findings highlight the promising formulation with 50/50 ratio of candelilla and rosin, demonstrating favorable results in dispersion, stability, viscosity, and lash curvature, offering insights for future mascara development.

## Keywords :

Mascara, direct emulsion, rosin, candelilla, formulation, characterisation, stability, capacity, film-forming, pine



*Mascara formulation put in tubes*

Contact(s) : laureen.joachim@etu.umontpellier.fr





# Quality management of a research laboratory

European Membrane Institute of Montpellier



Flore  
ROUSSEL

Flore ROUSSEL GBA

Academic Supervisor : Céline Pochat-Bohatier



## Objective / Motivation :

Quality management is crucial in a research laboratory, ensuring compliance with standards and the credibility of scientific work. The MLab laboratory is specialized in the manufacture of membranes for water treatment and food technology. It's a partner of the European INNOMEM project and must therefore meet the expectations developed in the OASIS internal quality approach. The aim is to maintain the laboratory's safety, so it needs to implement actions in the fields of safety, risk management, quality and environmental impact.

## Results :

My role during this end-of-studies project was to set up safety procedures, create training tools and contribute to the day-to-day management of the MLab, in line with the internal OASIS procedure. My work involved content creation, analysis, reflection and creativity to meet the expectations of the European project, but also to meet manufacturer's expectations in industrial projects.

## Keywords :

Quality, Organizational skills, Security, Membrane.



Example of a safety data sheet implemented.

Contact(s) : flore.rousseau@etu.umontpellier.fr











# SOPRASTERIA - GOELAND PROJECT

Professionalization contract with Sopra Steria from 01/09/23 to 16/02/24

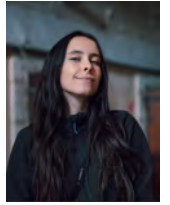

Laura  
BENAÏTON

Laura BENAÏTON IG

Academic Supervisor : Gwladys Toulemonde



## Objective / Motivation :

As part of a project for one of Sopra Steria's largest customers in the Telecommunications sector, Orange, we have to carry out upgrades in line with the business requirements prioritised by our customer. The aim of this project is to maintain and develop the GOELAND application, which automatically processes the after-sales service chain between Orange and other operators.

## Results :

During my work-study placement, I carried out a number of varied tasks. These ranged from database updates, unit and integration tests to feature development and support tasks for Orange.

## Keywords :

Orange, maintenance, upgrades, tests, processing



*Simplified diagram of applications on the Orange after-sales service chain.*

Contact(s) : [laura.benaiton@etu.umontpellier.fr](mailto:laura.benaiton@etu.umontpellier.fr)



# Music Sense

Music analysis and set assistance tool for DJs



Océan  
SICARD-BAUX

Sébastien CORTES *IG* Océan SICARD-BAUX *IG*

Academic Supervisor : Vincent Berry



## Objective / Motivation :

The software is a music analysis and assistance tool for DJs. The aim is to help them manage their music libraries and assist them in their DJ set creation.

## Results :

We made a functional prototype. We designed it and build it from scratch. We used open source algorithms and created some on our own to make this possible.

## Keywords :

DJ music analysis algorithm

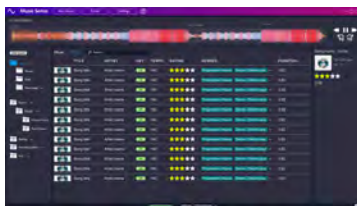

Library page

Contact(s) : [sebastien.cortes@etu.umontpellier.fr](mailto:sebastien.cortes@etu.umontpellier.fr) [ocean.sicard-baux@etu.umontpellier.fr](mailto:ocean.sicard-baux@etu.umontpellier.fr)



# Development of a web-based learning application

based on the "Who is it?"



Eri  
AGNESE

Eri AGNESE IG Lucas DARIE IG

Academic Supervisor : Lysiane BUISSON LOPEZ

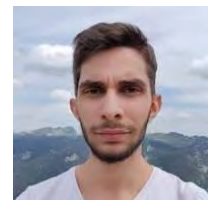

Lucas  
DARIE



## Objective / Motivation :

Our brief was to develop a game in the form of a web application. The aim of this application was to enable students to structure their thinking in a fun way, while guaranteeing the acquisition of knowledge. It is based on the principle of the famous board game "Who is it? The application had to be adaptable to any subject and include access for teachers, enabling them to add new sets of images. Administrator access to statistics was also required.

## Results :

In the end, we succeeded in implementing the features we had requested. Teachers can now create a quiz by adding their own images. Students can find the quiz when they create their game. Once in the game, a real-time chat is available to allow students to communicate. Administrators can then find the statistics for each quiz: number of games played, time taken, etc. The graphic design of the site was created by the IUT MMI in Béziers.

## Keywords :

game, web, full stack, NextJS, NestJS, React, TypeScript, Docker, Socket.io, websocket



Lobby page



In game page

Contact(s) : eri.agnese@etu.umontpellier.fr lucas.darie@etu.umontpellier.fr

# PRIAM - LIRMM RGPD

Development of an GDPR compliance assistance application



Alexis  
FONDARD MARTIN

Alexis FONDARD MARTIN /IG Dorian CORREIA-MATEUS /IG

Academic Supervisor : Esther PACITTI



Dorian  
CORREIA-MATEUS



## Objective / Motivation :

The research project aims to propose a solution for application developers to assist them in meeting the requirements of the GDPR (General Data Protection Regulation). This solution provides a set of microservices, each responsible for implementing an aspect of the GDPR: management of user consent, management of requests for rectification or the right to be forgotten, etc. The ultimate aim of the solution is to provide support for managing user privacy (compliance with the GDPR, in particular) in applications in the most automated way possible.

## Results :

First of all, a refactoring of the existant code according to the new meta model has been made. We've also implemented two scenarios corresponding to access, deletion and rectification of user data, on both the user and provider sides. We conceptualized and developed authentication using the OAuth2 flow, so that PRIAM users don't have to log in a second time. We have written a technical documentation for a global and precise understanding of the code, as well as a configuration document for the provider.

## Keywords :

GDPR, Microservices, Database-per-microservice Pattern, Micro-frontends



User frontend - Access right page

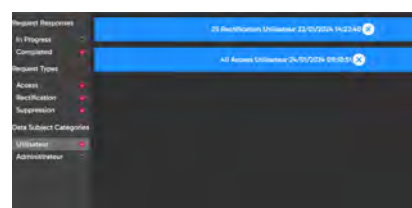

Provider frontend - Requests management page

Contact(s) : alexis.fondard@etu.umontpellier.fr dorian.correia-mateus@etu.umontpellier.fr



# Tradel - Financial markets investment support platform



Thomas  
FOURNIER

Monetize existing financial services through the creation of a mobile application

Thomas FOURNIER IG Ayoub HAKEMI IG

Academic Supervisor : Tiberiu Stratulat



Ayoub  
HAKEMI



## Objective / Motivation :

Tradel, a budding fintech, strives to revolutionize financial market access for novice investors. Its project involves crafting an intuitive investment assistance platform catering to individuals. Covering diverse assets like stocks, forex, and cryptocurrencies, its goal is to empower users with informed investment decisions. Our objective for this project was therefore to monetize existing financial services through the creation of a mobile application, integrating technical analysis and order management parts.

## Results :

We made significant progress on the project. We completed the setup of the entire backend infrastructure, thus laying solid foundations for the platform's functionalities. Additionally, notable strides have been made on the frontend, with the implementation of core features. Users can now easily register and log in, manage their accounts, and access investment advice, critical steps towards achieving a comprehensive user experience.

## Keywords :

Fintech - Mobile application - Investment - Trading - Financial markets - Assistance platform - Microservices architecture - React Native - Expo - Apollo GraphQL - NodeJS - PostgreSQL - MongoDB - SuperTokens - Student entrepreneurship project



Application imageries

Contact(s) : thomas.fournier@etu.umontpellier.fr ayoub.hakemi@etu.umontpellier.fr

# V2 de l'application mobile Grottocenter

V2 de l'application mobile Grottocenter



Dino  
GREIL

Dino GREIL IG Loris BOUCHEZ IG

Academic Supervisor : Philippe CHAPPELLIER

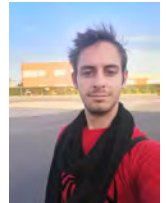

Loris  
BOUCHEZ



## Objective / Motivation :

The objective was to create a new version of the grottocenter mobile application. This new version should be available in several languages (the user should be able to switch languages easily) and implement functionalities that the users have asked for. This will make the application available to a wider audience and more useful.

## Results :

The application is now available in several languages. Several bugs have been fixed. A user can now send and access documents from the mobile application. The new version has been delivered on google play

## Keywords :

Grottocenter React Native Mobile Development Translation

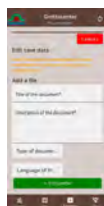

Document creation page translated in english

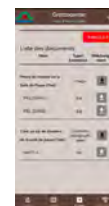

Downloading document page

Contact(s) : dino.greil@etu.umontpellier.fr loris.bouchez@etu.umontpellier.fr



# Interactive summary dashboard for a web application

Side panel containing charts to provide context to the user

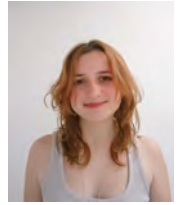

Alma  
SORRENTINO

Alma SORRENTINO IG Jason MORET IG

Academic Supervisor : Eleonora GUERRINI

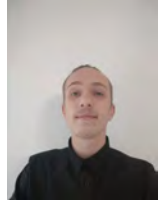

Jason  
MORET



## Objective / Motivation :

Go-Up! offers an interactive map of France, using public data such as Pôle Emploi, to guide demographic and business decisions. However, its data exploration is limited, not allowing for in-depth analysis. Our brief was to integrate an interactive side panel into the existing application. It would enable users to track the temporal evolution of parameters for a selection of areas and compare them with the overall territory. This mobile-friendly panel would include graphs and tables for visual representation of the data.

## Results :

We developed an interactive side panel in the Go-Up! application, allowing an analysis of the evolution of parameters for a selection of areas. We added procedures in the API, as well as Recharts for dynamic visual representation of evolutions and comparisons between selected areas and the whole territory. A system of tabs has been integrated for better organization of content. In addition, a cross-parameter comparison page has been developed, offering users the opportunity to explore and compare data in depth.

## Keywords :

Interactive side panel, Temporal evolution, Recharts, Tailwind, ReactJS, NextJS, tRPC, User experience, Data analysis, API, TypeScript, Dashboard, Hooks, Prisma, Recoil, Map

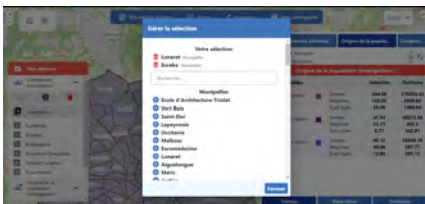

Area selection management



Evolution graph for a parameter

Contact(s) : [alma.sorrentino@etu.umontpellier.fr](mailto:alma.sorrentino@etu.umontpellier.fr) [jason.moret@etu.umontpellier.fr](mailto:jason.moret@etu.umontpellier.fr)





# Projectly

Application that improves financial management



Rachid  
FASKA

Rachid FASKA *IG* Louis VAN DER PUTTEN *IG*

Academic Supervisor : Christophe NAUROY



Louis  
VAN DER PUTTEN



## Objective / Motivation :

Our goal with Projectly was to simplify project management and leverage data for strategic decision-making. Motivated by the desire to streamline repetitive tasks and enhance financial management, we aimed to transform data into a strategic asset. Our vision encompassed automating processes and harnessing the power of artificial intelligence to drive more efficient utilization of project insights.

## Results :

An application with an interactive dashboard that summarises financial activities, making it easier to monitor and make decisions and an artificial intelligence capable of providing contextualised answers, guiding users towards judicious strategic choices.

## Keywords :

Project Management, Data Automation, Artificial Intelligence, Financial Management, Strategic Decision-Making, Data Insights, Process Optimization



Website Dashboard

Contact(s) : rachid.faska@etu.umontpellier.fr louis.van-der-putte@etu.umontpellier.fr





# Synthesis and characterization of a bioactive glass



Emma  
ALMUNIA

## Study of 45S5 bioactive glass

Emma ALMUNIA *MAT*

Academic Supervisor : Annelise Faivre



### Objective / Motivation :

45S5 is a glass widely used in the orthopaedic and dental sectors to aid bone regeneration. It is a bioactive material: it is capable of generating chemical bonds between the implant surface and the bone. In order to develop new biomedical applications of this material in collaboration with Noraker, it is very important to have a good knowledge of all this properties. The aim of this project is therefore to synthesize 45S5 glass, and characterize it using several methods to obtain its various properties.

### Results :

Glass samples have been synthesized using a conventional fusing process. Analysis using a scanning electron microscope coupled to an electron dispersion spectroscopy module verified that their composition was close to that of 45S5 glass. Thermal, optical (refractive index and constringence), mechanical (microhardness) and viscosity properties of these glasses were obtained using several characterization methods.

### Keywords :

Bioactivity / Bone regeneration / Thermal properties / Crystallization / Optical properties / Viscosity / Microhardness



45S5 glass synthesis by melting



Indentation imprint and cracks after application of a 1kg load

Contact(s) : emma.almunia01@etu.umontpellier.fr



# Life Cycle Analysis (LCA) for water electrolyzer design with membrane



Wassim  
BOUCCEREDJ

Assessment of the environmental impact of the life cycle of an AEM (Anion Exchange Membrane) electrolyzer for the production of one kilogram of hydrogen

Wassim BOUCCEREDJ *MAT*

Academic Supervisor : Jean-Louis BANTIGNIES

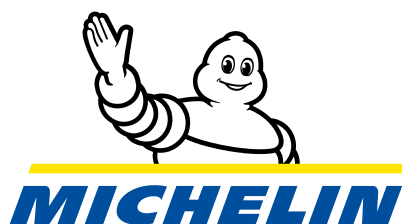

## Objective / Motivation :

Michelin, experts in materials, explores new domains, including energy, to promote sustainable mobility or to power industries. Hydrogen appears to be a highly interesting energy vector for electricity production via water electrolysis. This project aims to enlighten electrolyzer designers by providing a life cycle analysis (from raw material extraction to end-of-life) to assess their environmental impact. This initiative aligns with Michelin's commitment to offering innovative and responsible solutions.

## Results :

When examining a particular technology, the AEM (Anion Exchange Membrane) electrolyzer, it becomes evident that its usage phase has the greatest impact compared to other stages of its life cycle. The materials used, such as metals for electrodes, polymers for the membrane, and even steel for auxiliary equipment, have significant environmental impacts. This technology serves as a favorable alternative to steam reforming, especially when powered by renewable sources or the French energy mix.

## Keywords :

Hydrogen, water electrolysis, life cycle analysis, AEMWE electrolyzer (anion exchange membrane water electrolysis)

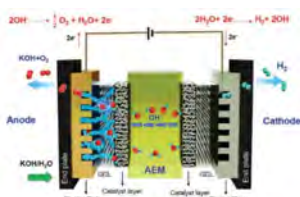

Operating principle of an AEM electrolyzer



Diagram of a product life cycle

Contact(s) : wassim.boucceredj@etu.umontpellier.fr



# Reduction of shrinkage in ultra-high performance fiber-reinforced concrete

using shrinkage reducing admixtures and super absorbant polymers

Coline BRÉMOND *MAT*

Academic Supervisor : Philippe PAPET



## Objective / Motivation :

Concrete usage worldwide accounts for 8% of global CO2 emissions. Cement is responsible for the majority of the emissions. Reducing the amount of cement used in a concrete mix implies replacing the cement with different materials. Holcim has developed a UHPC formula using nano-silica and other additives to replace some cement. The aim of this study will be to evaluate the impact of different types of shrinkage reducing additives on a Ductal® white formula that uses NS.

## Results :

Results have not been obtained for this project yet as it is an apprenticeship project. The results of this apprenticeship will be finalized in July. In addition, the results are confidential.

## Keywords :

UHPC, nanoparticles, shrinkage, concrete, cement, nano-silica



Central Bank of Iraq built using Ductal®



Mucem outer structure made with Ductal®

Contact(s) : coline.bremond@etu.umontpellier.fr



# Valorization of by-products from the leather industry

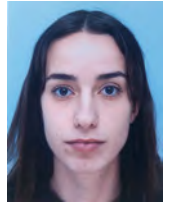

Léa  
CHARPENTIER

Léa CHARPENTIER *MAT*

Academic Supervisor : Ahmad Mehdi



## Objective / Motivation :

The objective is to find a new way to valorize the by-products of the leather industry, which are present in very large quantities. The goal is to create a new material through heat treatment.

## Results :

A solid with numerous cavities was produced through heat treatment at 140°C for 18 hours. The processing time was optimized at 180°C for 3 hours. The reactions involved are dehydration and carbonization, which can be observed through SEM and IR.

## Keywords :

heat treatment, leather shaving wastes, dehydration, carbonization, autoclave, scanning electron microscopy (SEM), infrared spectroscopy

Contact(s) : [lea.charpentier@etu.umontpellier.fr](mailto:lea.charpentier@etu.umontpellier.fr)



# Imaging study of the structure and mechanical behavior of bamboo.



Alexis  
COLOMBO

Materials science project

Alexis COLOMBO MAT

Academic Supervisor : Bertrand Watrresse / Jean-Michel Muracciole



## Objective / Motivation :

In the context of climate change, energy shortages and raw material shortages, bamboo, a natural material, is emerging as a potential solution. This study focuses on characterizing the structure and mechanical behavior. The aim is to provide information to feed mathematical models developed in the laboratory, facilitating structural calculations on these complex materials

## Results :

The structure of bamboo was characterized using MRI and X-ray tomography, revealing nodes and internodes. The culm is made up of vascular bundles of fibers, unevenly distributed and increasing in density towards the periphery. Bamboo nodes are made up of interlaced short fibers. Mechanical behavior was studied by compression. The results indicate a negligible influence of the nodes during bamboo compression.

## Keywords :

Imaging, image analysis, characterization

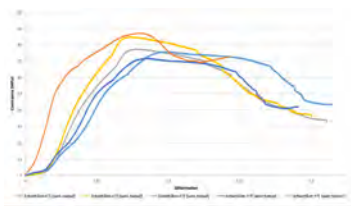

Conventional compression curves for bamboo samples with and without knots

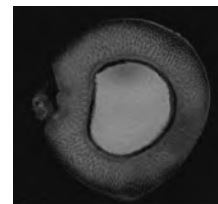

MRI image of an axial section of the bamboo wall

Contact(s) : alexis.colombo@etu.umontpellier.fr





# Study of the microstructure of oxide ceramic matrix composites



Valentin  
DURAND

Determination of the grain size, crystalline orientation and porosity

Valentin DURAND *MAT*

Academic Supervisor : Nicole Fréty, Fabrice Barou



## Objective / Motivation :

The objective of this project is to observe the microstructure of ceramic matrix oxide composites using Scanning Electron Microscopy (SEM) coupled with Energy X-ray Dispersion Spectrometry (EDS) and Electron Back-Scattered electron diffraction (EBSD) to study the chemical composition and local crystalline structure.

## Results :

The grain size, local crystalline orientation and porosity were analysed for the different samples. These results can then be compared in order to determine a way of upgrading the quality of these materials.

## Keywords :

Oxide Ceramic Composites, Microstructure, SEM, EDS, EBSD

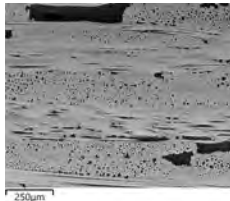

SEM observation of a ceramic matrix oxide composite (x100)

Contact(s) : valentin.durand@etu.umontpellier.fr



# Study of the real added value of bio-based antioxidant molecules on the thermal stability of various polymer materials



Maëva  
FERNANDEZ

Materials Science

Maëva FERNANDEZ *MAT*

Academic Supervisor : Jean-Pierre HABAS



## Objective / Motivation :

In materials science, an antioxidant is a chemical additive whose primary function is to prevent or slow down the oxidation process in polymers. Oxidation is a chemical reaction that occurs when polymers are exposed to oxygen, heat or light, and can lead to physical and chemical degradation. Currently, the majority of antioxidants used by manufacturers are derived from petroleum chemistry. This project aims to identify natural antioxidants that can be successfully used in blends in different thermoplastic polymers.

## Results :

A bibliographic study was carried out to identify a bio-based antioxidant molecule with the same properties as petroleum-based molecules. A molecule with a priori high potential and reasonable cost was selected. Its thermal and chemical behaviour was characterised by DSC, ATG and FTIR spectroscopy. Accordingly, two thermoplastic polymers were selected for evaluation. Blends were prepared with different rates ratio of antioxidant and according to different moulding temperatures. Thermal stability was observed for further characterisation.

## Keywords :

Antioxidants - Polymers - Thermal stability - Viscosity - Processibility



*Blend of thermoplastic polymer and antioxidant*

Contact(s) : [maeva.fernandez@etu.umontpellier.fr](mailto:maeva.fernandez@etu.umontpellier.fr)



# Nanospheres for the local and controlled delivery of active ingredients (PA)



Pierre  
HUGON

Characterization of nanoparticles and study of toxicity by implantation of particles in living cells

Pierre HUGON *MAT*

Academic Supervisor : Rozenn LE PARC / Jean-Louis BANTIGNIES



## Objective / Motivation :

The fundamental objective of this project is to characterize mesoporous hollow hybrid silica nanoparticles for biological application as an agent capable of releasing active principles or as a temperature sensor in a cell.

## Results :

This study allowed to characterize the chemical composition and structure of nanoparticle samples. In parallel, a biological study demonstrated the ability to inject particles into living cells as well as the low toxicity of particles in a biological environment.

## Keywords :

hybrid silica nanoparticles, IRTF, DRX SAXS, RMN, RAMAN

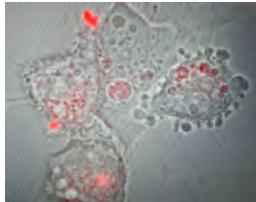

*Photography of particles in a living cell*

Contact(s) : pierre.hugon@etu.umontpellier.fr



# professionalization contract

Composite materials of today and tomorrow

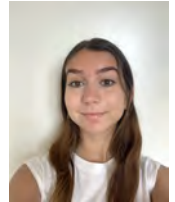

Olivia  
LEJEUNE

Olivia LEJEUNE MAT

Academic Supervisor : GILLES GUERRERO



Capgemini engineering

## Objective / Motivation :

The aim is to work on composite materials through R&D and customer activities. Research is a window for the company, enabling it to promote its activities to customers. Customer activities meet the needs of customers who call on us, notably for the qualification of composite materials for the aeronautics industry.

## Results :

For research purposes, we're developing a new mycelium-based composite material that could replace the concrete bricks used in construction. These bricks have excellent acoustic, thermal and mechanical properties.

## Keywords :

Research, mycelium bricks, construction sector

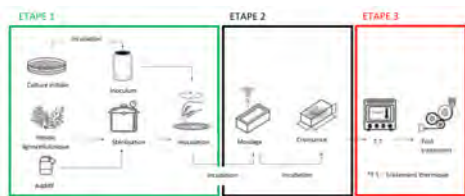

mycelium brick manufacturing process

Contact(s) : olivia.lejeune@etu.umontpellier.fr



# Work-study program - Mechanical calculation engineer

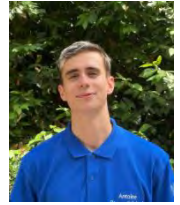

Antoine  
LUCHE

Seismic resistance of nuclear power plant equipment

Antoine LUCHE *MAT*

Academic Supervisor : Bertrand WATTRISSE



## Objective / Motivation :

The objective of this work-study basis is to validate the seismic dimensioning of equipment for integration in nuclear power plants. In a general way, the objective is to be familiar with seismic calculations, by working on basic structures and equipment, to allow me doing some calculation on complex structures like transfer tube in the future.

## Results :

I'm only at the half of the work-study formation but I start to be familiar with Computer-aided design (CAD) software, and also with nuclear notions. I can't present some results for the moment but at the end, the result will be the validation of seismic dimensioning of equipment for integration in nuclear power plants.

## Keywords :

Nuclear, mechanical, Computer-Aided Design (CAD) Software, calculate

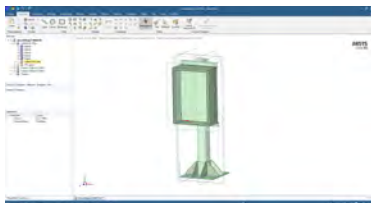

*CAD assembly of an electrical cabinet and its chassis*

Contact(s) : antoine.luche@etu.umontpellier.fr



# Development of a very low-flow collision system for bi-component reactive spraying



Jean  
PASTOL

Jean PASTOL *MAT*

Academic Supervisor : Eric ANGLARET



L'ORÉAL  
PARIS

## Objective / Motivation :

Creation of metastable water/oil emulsion without surfactants through the use of a Gjosa shower using jet collision technology. These emulsions are obtained by passing the solution a number of times through the shower.

## Results :

The experimental results give emulsions which are relatively stable even after 45 minutes for a number of passes greater than 2 or 3 depending on the oils used.

## Keywords :

metastable emulsion, jet collision, Gjosa shower

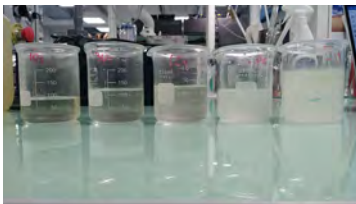

*Oil in water emulsion sampled at various time and after 45 minutes at rest*

Contact(s) : jean.pastol@etu.umontpellier.fr





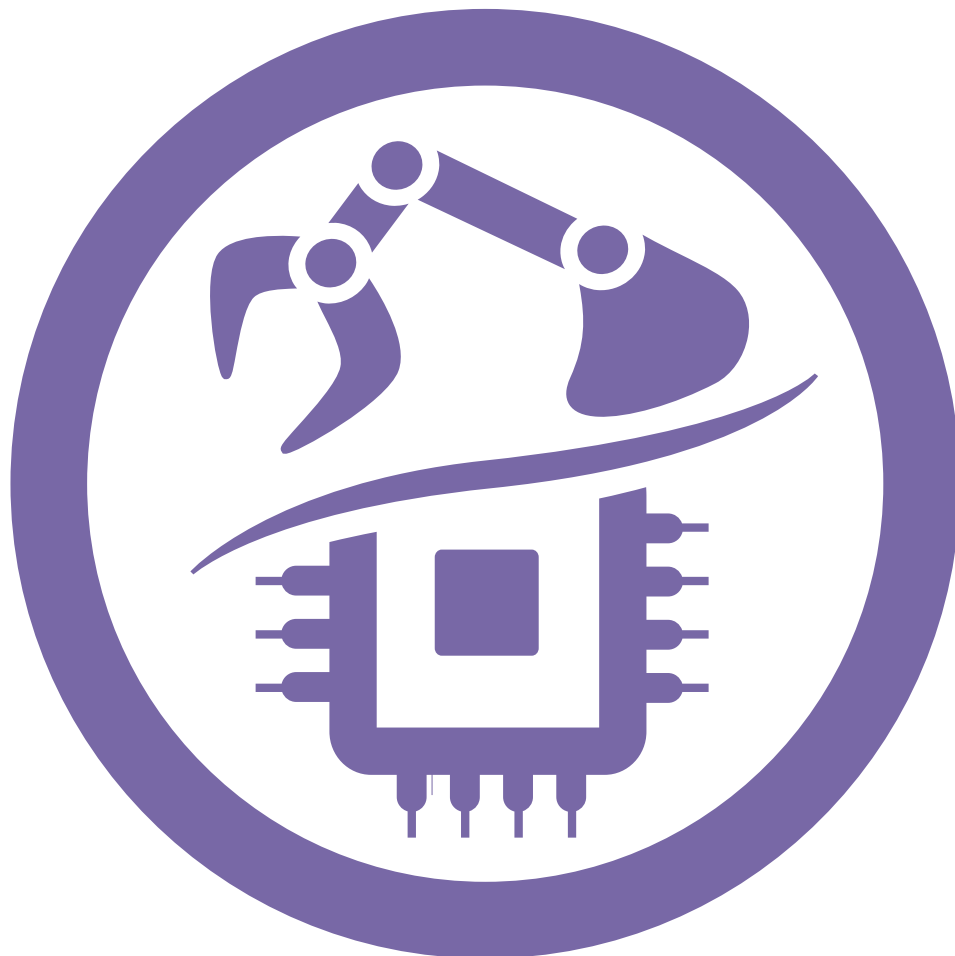





# Characterisation of elastomers for the design and manufacture of an articulated finger

Materials science

Corentin PIOT *MAT*

Academic Supervisor : Vincent Lapinte



## Objective / Motivation :

The goal is to perfectly characterise the mechanical behaviour of a silicone elastomer in order to be able to dimension the finger actuator with this material. The second point is to compare this material with another elastomer using photopolymerisation as the manufacturing process, which would enable more complex shapes to be manufactured, particularly using the stereolithography technique, if it meets expectations.

## Results :

Two elastomers were studied: EcoFlex 00-10 silicone and Ultracur3D polyurethane acrylate. Following mechanical testing, the silicone elastomer was found to be the most suitable due to its excellent elasticity and reversible deformation. Polyurethane acrylate, on the other hand, is not sufficiently deformable and is not reversible.

## Keywords :

EcoFlex 00-10 silicone, Ultracur3D polyurethane acrylate, reversible deformation, mechanical characterisation



*EcoFlex silicone and Ultracur3D polyurethane acrylate*

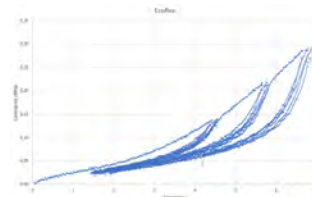

Contact(s) : [corentin.piot@etu.umontpellier.fr](mailto:corentin.piot@etu.umontpellier.fr)



# Optimisation of X80 linepipe steels for the transport of gaseous dihydrogen



Clément  
SALLES

Materials Science

Clément SALLES TMA

Academic Supervisor : Laurent WALTZ



## Objective / Motivation :

The aim of this project is the study and the optimisation of a steel pipe for the transport of gaseous dihydrogen. The goal is to emphasize on the effects of the hydrogen embrittlement mechanisms by realizing bibliographical searches. In order to reinforce the resistance of the steel against the hydrogen, a surface hardening treatment will be performed and evaluated. The increasing demand for hydrogen requires the development of materials solutions to reduce manufacturing costs and to increase the quantity of hydrogen transported.

## Results :

According to the literature review there are four main mechanisms of hydrogen embrittlement, even if they all don't involve the same hydrogen populations it is believed that they work together. Regarding the experimental results, it has been observed that the weld zone has a different microstructure than the core of the steel, this could have an influence on the resistance against hydrogen. The surface hardening treatment led to the formation of a nanocrystalline layer at the surface resulting in the hardening of the treated region (~50µm).

## Keywords :

Surface hardening, hydrogen embrittlement, microstructure

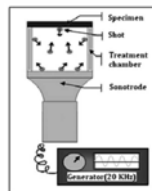

Schematic illustration of the surface hardening treatment [Jelliti et al. 2013]

SMATed surface x400 (scale = 10µm) Non SMATed surface x400 (scale = 10µm)

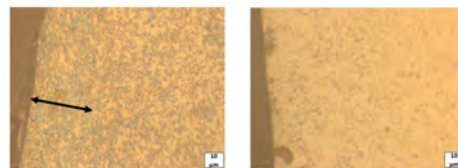

Effect of the surface hardening treatment on the microstructure

Contact(s) : clement.salles@etu.umontpellier.fr



# Physico-chemical characterizations and modeling of degradable polymer implants for a better understanding of degradation and controlled release of active principles.



Hamza  
SAMRI

Enhancement of the understanding of the degradation mechanism of poly(glycerol sebacate) by strengthening the comprehension of water uptake by PGS and water diffusion within PGS through complementary measures such as tensiometry and numerical simulations like molecular dynamics.

Hamza SAMRI *MAT*

Academic Supervisor : Laura Vasilica Arsenie

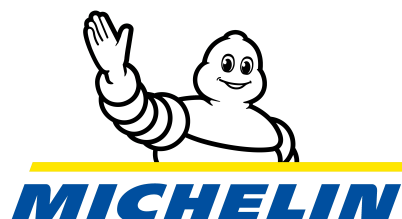

## Objective / Motivation :

Improving the understanding of the degradation mechanism of poly(glycerol sebacate) (PGS) involves measuring water uptake by PGS and calculating the water diffusion coefficient within the PGS matrix through simulations. This approach is crucial given that PGS degrades through a hydrolysis mechanism (breakage of ester bonds by water). This improvement in understanding aims to assist designers in the creation of PGS implants for controlled release of active principles.

## Results :

The first set of molecular dynamics simulation results shows that water diffusion increases as the PGS matrix is loaded with water. The water diffusion phenomenon appears to be self-accelerating. Initial results of water diffusion in PGS at high water content (50%) still yield diffusion coefficients lower than those of self-diffusion of water, indicating limited water mobility, notably due to the presence of the PGS matrix. As for the tensiometer, this possibility is currently under consideration and has not yet yielded any results.

## Keywords :

Poly(glycerol sebacate) (PGS), Degradation, Water uptake measurement, Simulations, molecular dynamics, tensiometry.

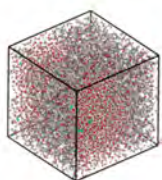

Simulation box representing the PGS matrix in the presence of water molecules.

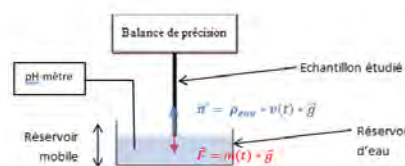
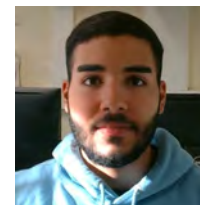

Diagram of the tensiometer principle.

Contact(s) : hamza.samri@etu.umontpellier.fr



# BIOPOLYMERS AS REPLACEMENT FOR POLYETHYLENE IN BUBBLE FILMS FOR PACKAGING



Ouday  
ZORKOT

Extrusion and characterization of biopolymers

Ouday ZORKOT *MAT*

Academic Supervisor : Caroline Vigreux



## Objective / Motivation :

This project aims to characterize various biopolymers from a thermal perspective, conduct extrusion tests, and mechanically characterize the extruded films to compare their properties with those of the currently used polyethylene, with the goal of identifying a suitable substitute.

## Results :

The assessment of biopolymers as substitutes for polyethylene in bubble packaging films has pinpointed the tested PBS as the most promising in terms of both mechanical strength and appearance, despite being five times more expensive. This highlights the dilemma between environmental considerations and budget constraints.

## Keywords :

Biopolymers, Bubble Films, Polyethylene, Extrusion, Characterization, Environmental Impact

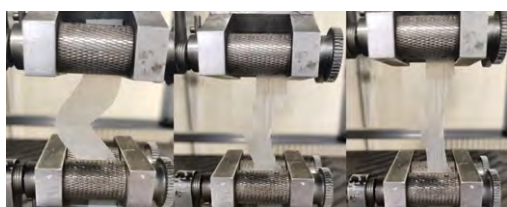

Images of the tensile test according to ASTM D1004 standard.

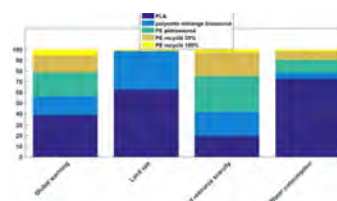

Life cycle analysis impact reported as a percentage for four indicators.

Contact(s) : [ouday.zorkot@etu.umontpellier.fr](mailto:ouday.zorkot@etu.umontpellier.fr)



# Robotic finger with soft Actuators

Microelectronics and Automation

Akram Benazzouz



Academic supervisors:

Philippe Fraisse

Microelectronics and Automation at Polytech Montpellier

---

## Objective/Motivation:

Choosing this project offers an exciting opportunity to delve into the forefront of materials science and engineering. Exploring the world of electroactive polymers promises to unravel new avenues for technological advancements, offering a dynamic journey at the intersection of innovation and discovery.

## Results:

The culmination of our efforts yielded promising outcomes. Through meticulous fabrication and characterization processes, we unveiled the unique properties of electroactive polymers. Our results demonstrate their potential in robotic applications, paving the way for future advancements in flexible electronics, soft robotics, and beyond.

**Keywords:** electroactive polymers, robotic finger, soft actuators, high voltage, automation

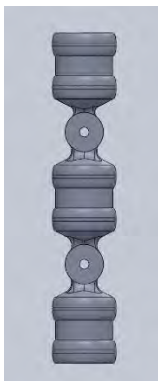

---

**Contact :** [akram.benazzouz@etu.umontpellier.fr](mailto:akram.benazzouz@etu.umontpellier.fr)

# Development of an immersive piloting system for drones



JérémY  
BEZANÇON

Virtual reality application

JérémY BEZANÇON *MEA*

Academic Supervisor : Michel Facerias



## Objective / Motivation :

This project aims to revolutionize military missions by developing an immersive drone piloting system using virtual reality goggles. It enhances operational efficiency by offering pilots a heightened perception of the environment, facilitating navigation and obstacle recognition. Additional goals include creating a 3D virtual human-machine interface to monitor mission progress and interact intuitively with drone control systems.

## Results :

The project achieved its main objectives by integrating video transmission from a drone into a virtual reality application, selecting appropriate virtual reality goggles and developing a system that replicates human vision for drone control. In particular, the technical challenges of video processing, data transmission and the integration of various technologies into a single application were addressed. One of the main results is a sophisticated man-machine interface that enables drones to be tracked in real time and immersed in them

## Keywords :

Virtual Reality, Drone Piloting, Immersive Technology, Human-Machine Interface, Video Transmission, Unity Engine, Stereoscopic Vision, Real-Time Monitoring, Technical Integration.



Utilisateur plongé dans la réalité virtuelle



Caméras stéréo reliés au drone terrestre

Contact(s) : jeremy.bezancon@gmail.com

# oxram optimization

Optimization of an OxRAM memory cell



**Baptiste  
CHATELIER**

**Baptiste CHATELIER** MEA

Academic Supervisor : **Pascal NOUET**



## Objective / Motivation :

The project focuses on OxRAM (Oxide Resistive Random Access Memory), which is an emerging non-volatile memory technology based on switching the resistance of an oxide. The main objective of OxRAM is to compete with Flash and DRAM (Dynamic RAM) memories. The aim of my project is to develop several test structures (TEGs) with different OxRAM memory array devices that have low power consumption and the smallest possible silicon footprint.

## Results :

The first stage of this project involved in-depth research to understand how OxRAM cells work. The second part of the development was the creation of test structure layouts. A block with 11 different TEGs was created, which has now been sent to production.

## Keywords :

OxRAM, non-volatile memory, TEG, memory array

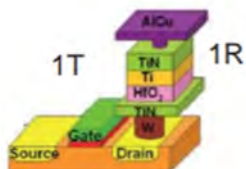

OxRAM cell

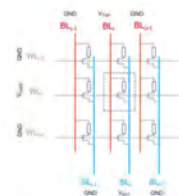

OxRAM memory array

**Contact(s)** : [baptiste.chatelier@etu.umontpellier.fr](mailto:baptiste.chatelier@etu.umontpellier.fr)





# e-POWER engine for aerial drone

Fly longer, recharge less often.



Antonin  
DELBOUYS

Antonin DELBOUYS *MEA*

Academic Supervisor : Eric Dubreuil



## Objective / Motivation :

Increasing the autonomy of our self-built drones significantly by adding a combustion engine to support the battery. Here, at the beginning of this ambitious project, the goal is to establish a solid foundation for a future project to build upon the work done.

## Results :

At the end of this project, we obtain a complete component chain, from the power source to the battery. Further work will be necessary to integrate all these components. For now, we are using brushless electric motors to simulate the effect of a combustion engine.

## Keywords :

e-POWER : Unlike a hybrid system, in an e-POWER system, the combustion engine solely serves to charge an electric battery, which in turn powers the entire drone's flight system.

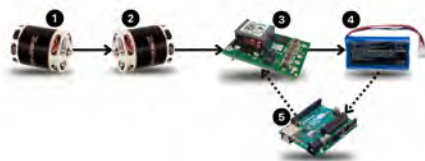

*Final component chain*

Contact(s) : [antonin.delbouys@etu.umontpellier.fr](mailto:antonin.delbouys@etu.umontpellier.fr)



# ROS2 3D SLAM + Navigation

Bunker Mini



Clément  
DIDIER

Clément DIDIER *MEA*

Academic Supervisor : Eric DUBREUIL



## Objective / Motivation :

The aim of this project is to map the robot's environment. The technique to be used is SLAM (Simultaneous Localisation And Mapping). It enables the robot to locate itself in an unknown environment while mapping it and adapting to it in order to navigate.

## Results :

The mapping of the environment in simulation and in real-life has been validated. It has been used to navigate the environment in a VR headset and for autonomous navigation. Autonomous navigation has been validated in simulation and started in real life.

## Keywords :

Autonomous navigation / SLAM / Mapping / Caterpillar robot / Simulation / ROS2

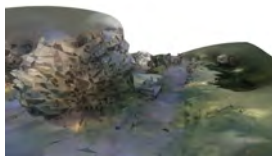

Reconstructed 3D map

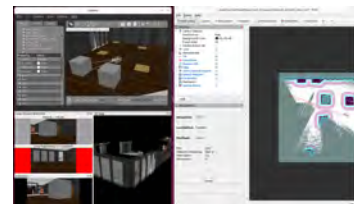

Simulation environment for autonomous navigation

Contact(s) : [clement.didier@etu.umontpellier.fr](mailto:clement.didier@etu.umontpellier.fr)



# Instrumentation of a micro-earthquake study bench



Sébastien  
DOYEZ

Création of a HMI and a code on Teensy 4.1

Sébastien DOYEZ MEA

Academic Supervisor : Mariane Comte



## Objective / Motivation :

Earthquakes are responsible for very significant human and material losses. The Peripacific area is one of the most affected areas, accounting for 80% of global seismic activity. One of the most devastating earthquakes was the Tohoku earthquake(2011) in Japan, which killed 15,900 people and caused damage estimated at hundreds of billions of dollars. Their predictions are therefore an important issue. With this project, seismologists will create a modeling of the phenomenon around the hypocentre.

## Results :

We managed to create a system composed of 2 accelerometers, thus allowing the measurement of microearthquakes using the replica created by Geoscience. Our original idea was to use the serial port to transfer the data. But this led to a lot of data loss, so we redirected to writing to SD card. A graphical interface has been created, this one still works with the serial link (with loss), its goal will be to have a visual control over the course of the experiment. The seismologist, at the end of this, retrieves the data directly from the SD card.

## Keywords :

Earthquakes modeling, Sensors Network, Study Bench, Seismic Waves Propagation

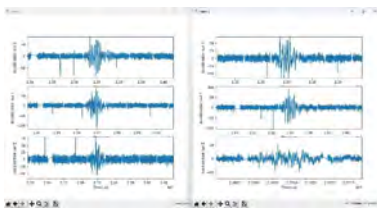

Measurement on a micro-earthquake



Model used for the study of micro-earthquakes

Contact(s) : [sebastien.doyez@etu.umontpellier.fr](mailto:sebastien.doyez@etu.umontpellier.fr)



# Manufacture of a Li/Ion and Ni/Mh battery discharge controller.

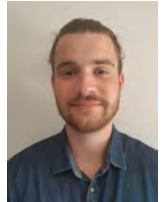

Luka  
DUFFAUT

Manufacture of a Li/Ion and Ni/Mh battery discharge controller.

Luka DUFFAUT *MEA*

Academic Supervisor : Michel Facerias



## Objective / Motivation :

The project aims to develop a product that can characterize an electrochemical accumulator to facilitate better usage, efficient sorting, and regular maintenance.

## Results :

The final product is not completed yet. PCBs have been developed for the testing phase. The theoretical aspect is more elaborated than the practical and prototyping part.

## Keywords :

Project, Characterization, Electrochemical accumulator, Prototyping, Battery, Charge, Discharge, Monitoring, High Current, Li/Ion, Ni/Mh, Controller



3D modeling of the final product. In the testing phase.

Contact(s) : luka.duffaut@etu.umontpellier.fr



# Deposition, dispersion, and characterization of CNT-FET

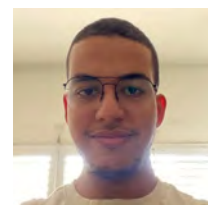

Mohamed  
EDMANE

PFE 2023/2024

Mohamed EDMANE *MEA*

Academic Supervisor : Fabien SOULIER / Mariane COMTE



# LIRMM

## Objective / Motivation :

1) The study involves examining various aspects of CNT-FETs. 2) Alignments of carbon nanotubes are performed through dielectrophoresis in a cleanroom. 3) Electrical characterizations on CNT-FETs are conducted in a testing room after dielectrophoresis in a cleanroom to compare their electrical performance, with a particular focus on the drain current ON/OFF ratio and threshold voltage.

## Results :

1) Images obtained with the scanning electron microscope of block CNT-FETs showing the alignment of CNTs. 2) Appearance of the electrical characteristics of CNT-FETs.

## Keywords :

CNT-FET, dielectrophoresis, carbon nanotubes, electrical characterization

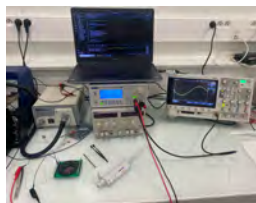

1) Alignment of carbon nanotubes through dielectrophoresis.

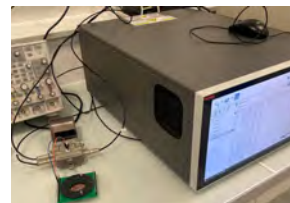

2) Electrical characterization of CNT-FETs.

Contact(s) : mohamed.edmane@etu.umontpellier.fr



# Grape measuring clamp

PFE 2023/2024



Anas  
ELKARKOUR

Anas ELKARKOUR MEA

Academic Supervisor : François Mirabel



# INRAE

## Objective / Motivation :

This project aims to innovate viticulture by developing a handheld device that accurately gauges grape maturity through mechanical resistance tests, determining the perfect harvest moment. It features data storage and GPS mapping, ensuring energy efficiency for extensive field use. The device promises to revolutionize harvest strategies by providing accurate, real-time maturity data, ultimately improving wine quality.

## Results :

The project successfully delivered a handheld system capable of accurately determining grape maturity by measuring the force applied to grapes via a motor mechanism. Essential data from these tests are stored efficiently on a microSD card. The device's energy consumption was thoroughly evaluated, showcasing its suitability for prolonged use in vineyard conditions and marking a significant advancement in precision agriculture for grape harvesting.

## Keywords :

Grape maturity assessment Portable device Force measurement Motorized system Data storage MicroSD integration Energy consumption Viticulture technology Precision agriculture Harvest optimization

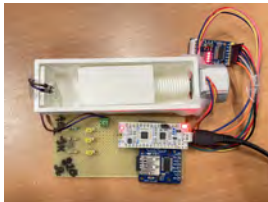

Final system overview

Contact(s) : [anas.elkarkour@etu.umontpellier.fr](mailto:anas.elkarkour@etu.umontpellier.fr)



# IO-Home control retro engineering for an implementation low speed PLC



Gawen FOLLET

Academic supervisors:

Michel FACERIAS

## Objective/Motivation:

The main objective of this last year project was to analyse the power line communication technologie, unsterstand how does it work and plan how to create a PLC module. Then to retro ingeneer the IO-Home Control protocol and find it's structure to state if it's a good choice for an implementation as a protocol on PLC.

## Results:

We have a full understanding of how does a PLC module work and how we can recreate one. We have conclude that using IO-Home Control isn't the best choice for an implementation on PLC due to it's closed status and the presence of some security breaches.

**Keywords:** Power Line Communication, IO Home Control, Retro Engineering, Home Automation

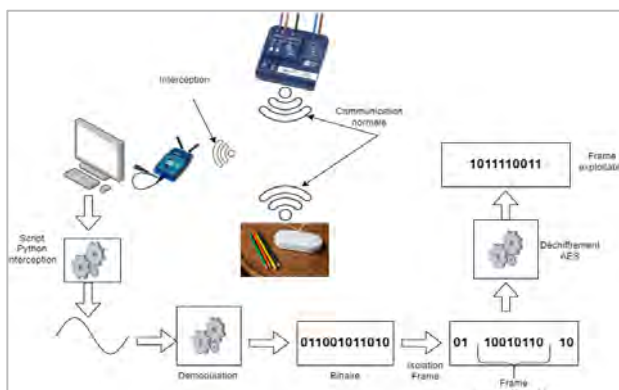

*(first) Test made to retro engineer IO-Home Control protocol / (second) PLC module used to analyse the technologie*

**Contact :** [gawen.follet@etu.umontpellier.fr](mailto:gawen.follet@etu.umontpellier.fr)

# Performance Evaluation NoC DDR on Versal

Study of the next generation of FPGAs proposed by AMD



Tom  
FOUREL

Tom FOUREL *MEA*

Academic Supervisor : Jeremie Arguel / David Novo



## Objective / Motivation :

This study focuses on the development of FPGA skills through the use of Versal technology and, more specifically, the Network on Chip it integrates. The objectives focus on performance in data transfer through the NoC, and should enable us to determine whether this technology is of interest.

## Results :

The study yielded significant results in the acquisition of skills necessary to configure the Network on Chip (NoC) and effectively utilize Versal technology.

## Keywords :

Versal, Network on Chip, FPGA, AMD, Xilinx, Microelectronics, Digital



Versal Xilinx Logo



Architecture of Versal SoC

Contact(s) : tom.fourel@etu.umontpellier.fr





# Optimization of LoRa communication for embedded system



Wael  
HAMILA

"HERMES"

Wael HAMILA MEA

Academic Supervisor : Paul LELOUP



LIRMM



## Objective / Motivation :

The objective of the project is to enhance LoRa communication between various modules and the gateway of an electronic device, facilitating seamless communication between individuals with reduced mobility and their life assistant in a nearby, though not immediate, environment. This improvement is achieved through the implementation of an AI algorithm (UCB). At each time point (t), the AI algorithm will strategically choose the most suitable channel, considering its busyness, and this selection will be based on previous communications.

## Results :

Before implementing the UCB algorithm on the embedded system, I developed a MATLAB simulator to assess its performance, examine its limitations, and compare them with standard channel selection methods. The simulator can model the system in various environments and scenarios, considering all real-life constraints. The algorithm has been validated as effective and implemented on the embedded system. The next step is to establish a test bench to evaluate its real-life performance.

## Keywords :

Artificial Intelligence, Reinforcement Learning, Machine Learning, UCB (Upper Confidence Bound), LoRa Communication, Embedded Systems, STM32, C Programming Language



The various modules of HERMES and the gateway.

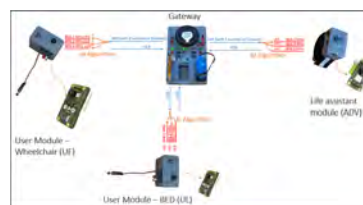

Channels used and the channel selection mode with AI

Contact(s) : wael.hamila@etu.umontpellier.fr

# ROS2 SENSOR FUSION

Improve location accuracy

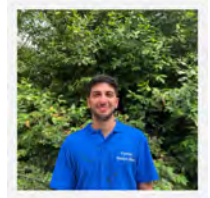

Aymen  
MKHARBACH

Aymen MKHARBACH *MEA*

Academic Supervisor : Eric Dubreuil



## Objective / Motivation :

This project focuses on the exploration and in-depth understanding of advanced data fusion techniques, with the aim of integrating and optimizing them within the ROS2 environment to meet the specific requirements of the COHOMA project.

## Results :

We have successfully implemented the data fusion package, gaining a generally satisfactory understanding of the working environment. However, experiments with real sensors reveal that these tools have certain limitations, particularly when faced with sensors whose uncertainties are too large to be fully compensated for. This underscores the need to assess and understand the accuracy limits of data fusion-based localization and navigation systems in real-life contexts.

## Keywords :

Multisource Data Fusion Establishing a Global Reference Framework Uncertainty management Sensory Data Transformation

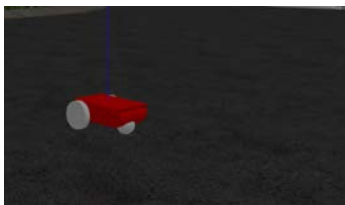

Three-legged robot used for simulation

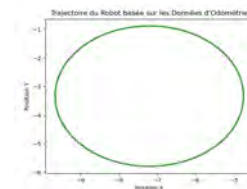

Circular robot trajectory with odometry data merged with IMU

Contact(s) : [aymen.mkharbach@etu.umontpellier.fr](mailto:aymen.mkharbach@etu.umontpellier.fr)

# PROVET-SST



## Modeling an energy-efficient digital AI accelerator

Swan  
NOBILI

Swan NOBILI *MEA*

Academic Supervisor : Paul DELESTRAC, David NOVO



LIRMM



### Objective / Motivation :

This ambitious project aims at creating a high-performance energy efficient accelerator to revolutionize AI applications. To do that we need to explore the realm of simulation modelling at the system level through the Proviet architecture that is using several components that interact harmoniously with each other. The entire model will be validated with

### Results :

I managed to the convolutional products from several components: • From VFU : 6 ns • From VWR : 14 ns • From SPM: 22 ns • From DRAM : 97 ns

### Keywords :

microprocessor microarchitecture, convolutional product, simulation framework (sst), compute unit



A configuration example of our Proviet accelerator

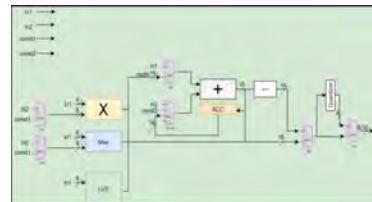

Comput Functional Unit

Contact(s) : swan.nobili@etu.umontpellier.fr



# ADAM: ADaptive Computing

Developing a Microcontroller for IoT and Edge Computing

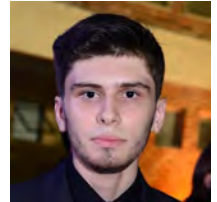

Felipe  
PAIVA ALENCAR

Felipe PAIVA ALENCAR *MEA*

Academic Supervisor : Pascal BENOIT



## Objective / Motivation :

My PFE aims to deepen the development of ADAM, an innovative microcontroller design adapted to IoT and Edge Computing. Initiated during an internship at LIRMM, ADAM evolves from ICOBS to address scalability challenges, enrich debugging capabilities, and establish a reproducible development framework via Docker, while emphasizing the importance of documentation and good version management practices.

## Results :

The project strengthened ADAM's scalability and debugging capabilities, while establishing a reproducible development environment using Docker. A major contribution was the design of an energy-efficient interconnection, which distinguishes between high and low speed domains, optimizing energy management. This included the successful integration of RISC-V cores and the revision of the Activity Pause Protocol. Comprehensive documentation and strong version control practices also highlight the commitment

## Keywords :

ICOBS, Microcontroller, IoT, Edge Computing, LIRMM, Low-Power.



ADAM running on a FPGA

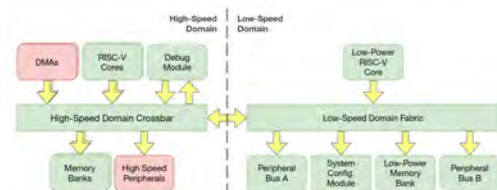

Interconnect Fabric of ADAM

Contact(s) : felipe.paiva-alencar@etu.umontpellier.fr

# Fermentation monitoring by impedance measurement



Matthieu  
PERRIN

Fermentation monitoring by impedance measurement

Matthieu PERRIN *MEA*

Academic Supervisor : Mariane Comte / Fabien Soulier



## Objective / Motivation :

Development and improvement of the impedance measurement system, with experiments on solutions containing the main parameters (sugar/alcohol/nitrogen) presents in fermentation, and analysis of the effect of these parameters on impedance measurements. The aim is to be able to precisely monitor impedance during fermentation, and to obtain results that allow us to situate ourselves in this process, in the manner of a CO<sub>2</sub> release system.

## Results :

The results obtained enable impedance to be monitored in single-parameter environments, but there are difficulties in multi-parameter analysis due to the ability of nitrogen to render a water solution ionized, and therefore highly conductive. Dynamic fermentation monitoring has been carried out, with promising results.

## Keywords :

Impedance, fermentation, system characterization, sugar, alcohol, nitrogen



Poster created for the project

Contact(s) : [matthieu.perrin@etu.umontpellier.fr](mailto:matthieu.perrin@etu.umontpellier.fr)



# Software Radio



Alexandre  
RIDOLFI

## Long-distance radio communication through vegetation

Alexandre RIDOLFI *MEA*

Academic Supervisor : Eric Dubreuil and Arnaud Vena



### Objective / Motivation :

The current aim of the project is to create a program that runs directly on the plutoSDR, so as to gain even greater performance and be able to communicate without having a computer connected to the plutoSDR.

### Results :

For now, what we've done is send a data frame with a preamble and data. The reception part is only realized with GNU radio for the moment.

### Keywords :

Software Defined Radio.



*The plutoSDR I used for the project*

Contact(s) : alexandre.ridolfi@etu.umontpellier.fr



# Drone Simulation Environment

Development of a simulation environment following on from the CoHoMa project, created by the French army



Romain  
SALVAGNI

Romain SALVAGNI MEA

Academic Supervisor : Eric Dubreuil



## Objective / Motivation :

One of the problems associated with my work was the lack of intensive testing of UAVs during the design phase. Our control programmes were limited by their ability to undergo rapid and repetitive tests, which are essential for complete and reliable development. Faced with this constraint, the adoption of advanced simulations appeared to be a relevant solution for overcoming the limitations of physical testing and improving our design process.

## Results :

In line with the first objective, this project has developed a method for using any UAV, its characteristics and its sensors in a simulator and integrating an environment corresponding to the needs of the mission. Then, ROS2 was implemented to the maximum of what is feasible. Using intermediate software, ROS2 now extends from an operator's computer right through to the drone's flight controller.

## Keywords :

CoHoMa Drone Gazebo PX4 PX4-Autopilot ROS2 Linux C++ Python



The drone used



Contact(s) : [romain.salvagni@etu.umontpellier.fr](mailto:romain.salvagni@etu.umontpellier.fr)



# Vegetation study tool

## Distance sensor for Herbs growth

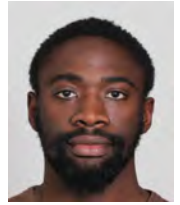

Meissa  
SECK

Meissa SECK *MEA*

Academic Supervisor : Eric DUBREUIL



### Objective / Motivation :

During my fourth-year internship at Davele, I worked on diverse projects, including an NDVI calculation system in Python for plant health analysis. Inspired by this, I chose a related theme for my end-of-studies project. The objective is to develop a system for monitoring plant growth in agrivoltaics, aligning with the synergy between agriculture and photovoltaic energy. The project aims to create an autonomous, battery-powered system that measures distance, generates quantitative growth data, and logs this information for future analysis.

### Results :

This device is an electronic system featuring a ToF VL53L5CX distance sensor, a DS1307 RTC, a common anode RGB LED, and an MKR ZERO card with an SD card port. Operating like a data logger, it provides a visual signal. Designed for measuring distance in a specific area proportional to the sensor's height, it records data in a 4x4 matrix format onto an SD card at specific intervals. Three files are saved for each data capture: raw data, evolving average, and evolving standard deviation. Davele analyzes these recorded data for robust statistics.

### Keywords :

Electronic system, distance sensor, ToF VL53L5CX, RTC DS1307, RGB LED, data logger, visual signal, measurement, SD card, statistical study, plant growth, battery-powered, 10,000mAh, optimal measurements, sleep mode, time management, Arduino MKR ZERO.



Mise en marche



en cas de problème

Contact(s) : [meissa.seck@etu.umontpellier.fr](mailto:meissa.seck@etu.umontpellier.fr)





# Design and characterization of an embedded solution for solar energy harvesting.

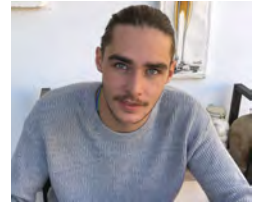

Timote  
SICARD

Solar harvesting

Timote SICARD *MEA*

Academic Supervisor : Laurent LATORRE



# LIRMM

## Objective / Motivation :

The project aims to design and assess a solar energy harvesting solution. It involves creating shields to characterize energy transfer between solar panels and a battery, followed by programming for measurement and LoRa-based data transmission protocols. Designing a real-world testing box is another key aspect. The motivation stems from a keen interest in renewable energy, passion for technology, and a desire to advance in programming and electrical circuit design.

## Results :

Study on solar panel-to-battery energy transfer revealed success with four circuits (SPV1050 boost, buck-boost, LTC3105, LTC4070). LTC4070 excelled in power at 65.7 mW, while SPV1050 in boost mode showed fast charging, though less practical for compact devices. Initial LTC3105 tests revealed slow charging. Limited tests with fewer solar cells yielded inconclusive results due to time constraints.

## Keywords :

solar energie,solar harvesting, power, current , dashboard, grafana, InfluxDB,STM32



solar panel



Shield

Contact(s) : [Timote.sicard@etu.umontpellier.fr](mailto:Timote.sicard@etu.umontpellier.fr)





# H175 Ice Protection System – Stop harness assembly static and fatigue analysis



Jimmy  
BISOU

During the flight test of the H175 de-iced main rotor blades, the aircraft will be equipped with a prototype ice protection system (IPS) and the system has to be verified.

Jimmy BISOU *MI*

Academic Supervisor : Yann Monerie, Benjamin Nouhaud



## Objective / Motivation :

The purpose of this note is to substantiate in static and fatigue the Stop Harness assembly and its links under aerodynamics and inertial loads due to critical maneuvers. A finite element model will be created in order to do process fatigue and static analysis. A lot of load case will be tested to be sure that the assembly can resist in all cases.

## Results :

The finite element model give us all the value of the stress for all cases, then the life time and the static margin has been calculated. The result shown that the assembly is correctly designed in fatigue and static analysis for all load cases. So the whole assembly can follow the process of creation.

## Keywords :

node mesh helicopter FEM fatigue static analysis

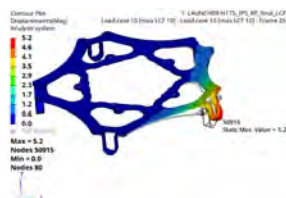

Displacement on the assembly

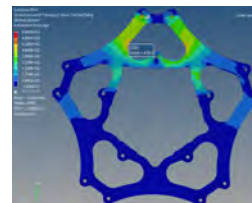

Traction Stress of the harness

Contact(s) : jimmy.bisou@etu.umontpellier.fr



# Characterization of a prototype for hanging and preserving free-painted canvas



Grégoire  
DUMONT

Innovative Hanging System: Assessment of Carole Husson's  
Prototype Viability

Grégoire DUMONT *MI*

Academic Supervisor : Vincent HUON / Frédéric DUBOIS



## Objective / Motivation :

Painted free canvases, devoid of frames, pose challenges in terms of hanging and preservation due to the use of hanging systems and experimental devices that can damage the artworks. To address this issue, it is essential to conduct tests aimed at characterizing the mechanical behavior of a new prototype hanging system and its components when subjected to various external stresses, in order to assess its viability and anticipate irreversible creases.

## Results :

The system underwent various tests. These results have enabled the establishment of a materials database for future numerical simulations. The analysis of different parameters aims to prevent irreversible deformations. Furthermore, tests conducted on the magnetic strip have confirmed its viability: It is recommended to wrap the neodymium strip in the reinforcing material to reduce the required peel force. This also allows for a self-locking effect in case of adhesive failure of the magnetic strip.

## Keywords :

- Artwork, free canvas, hanging system, magnetization, neodymium, tensile test, shear test, reinforced canvas, non-woven fabric, numerical simulation, material behavior, bending under self-weight, bending stiffness, deformation, imaging.

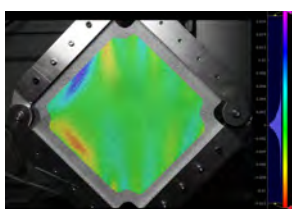

Visualization through imaging of shear-related deformations in a painted canvas

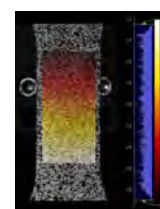

Visualization through imaging of the displacement field in a painted canvas specimen subjected to tension

Contact(s) : [gregoire.dumont@etu.umontpellier.fr](mailto:gregoire.dumont@etu.umontpellier.fr)



# Design and simulation of an exhaust muffler system for a racing car

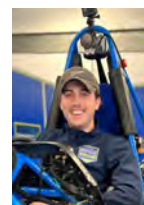

Malo  
ENEL

Funyo SP05 racing prototype

Malo ENEL *MI*

Academic Supervisor : Yvan Duhamel



## Objective / Motivation :

Find a high-performance exhaust muffler solution to comply with FFSA 2028 (Fédération Française des Sports Automobiles) regulations and obtain 95 dB at the tailpipe on the Funyo SP05 racing prototype.

## Results :

Proposal of 3 new solutions that are effective at low frequencies while absorbing a wide range of frequencies. These solutions have been designed following simulations of different silencer geometric configurations and the establishment of a list of the best performing configurations.

## Keywords :

Acoustic, CAD, CFD, Racing car, Muffler, Exhaust

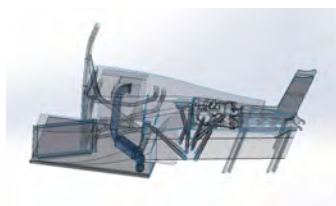

CAD environment of the car with the basic exhaust solution.

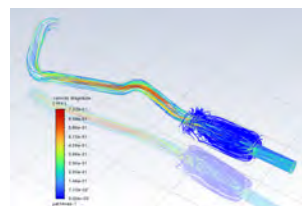

Velocity pathlines in the solution exhaust 2.

Contact(s) : malo.enel@etu.umontpellier.fr



# Studies Engineer Apprenticeship Contract

## Design of a special-purpose automatic wiring machine



Thomas  
FAVRET

Thomas FAVRET *MI*

Academic Supervisor : Aurélie Marchal



### Objective / Motivation :

Within the design office, this project involved a feasibility study of an automation process for wiring in certain critical stages. Initially, it was necessary to assess the criticality of these stages and determine their relevance or otherwise in this study.

### Results :

These initial weeks of the apprenticeship contract have allowed for finding technical solutions to address this issue, designing them on a computer using Solidworks, and then manufacturing and assembling the machine. Subsequently, tests must be conducted on production samples to validate or reject the process.

### Keywords :

Design, Special-purpose machine, Solidworks

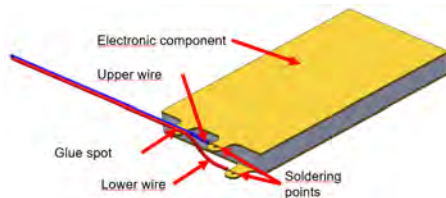

*Final assembly to be carried out*

Contact(s) : [thomas.favret@etu.umontpellier.fr](mailto:thomas.favret@etu.umontpellier.fr)



# Studies related to the development of packaging concepts for radioactive materials



Mathéo  
GARDES

Mechanical Engineering and Interactive Design

Mathéo GARDES *MI*

Academic Supervisor : Mathilde Cretet / Aurélie Marchal



## Objective / Motivation :

1. Participate in studies related to the development of new or existing radioactive material packaging concepts. 2. Drafting or updating safety documents in connection with requests for extension of packaging use.

## Results :

1. Creation of a new cap design for nuclear packaging model FS47. This will be tested, validated and then implemented on new models. 2. Drafting of the request for validation by the nuclear safety authority for the FS47 packaging.

## Keywords :

Nuclear, Mechanical engineering, Design

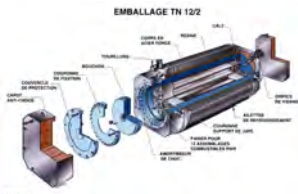

Composition of a nuclear fuel package

Contact(s) : [matheo.gardes@etu.umontpellier.fr](mailto:matheo.gardes@etu.umontpellier.fr)





# Implementation and Analysis of the Growth and Remodeling (G&R) Model in Biomechanical Problems Relating to Aortic Health



Romain  
GAYRAUD

Romain GAYRAUD *MI*

Academic Supervisor : Cristina Cavinato / David Li



## Objective / Motivation :

Exploit a G&R constrained mixture model to study the impact of pathological conditions on the structure and functions of the aorta via 1. Implementing the model in a framework of finite elements 2. Validation with experimental data 3. Analysis of the results to identify potential treatments

## Results :

The G&R mathematical model for simulating aortic aneurysms related to the Marfan syndrome, incorporates aortic pathological remodeling using finite elements. Experimental data reveal abnormal values in mice affected by Marfan syndrome, suggesting microstructural degeneration. The objective is to fit the numerical curves to mechanical experimental data by optimizing the constitutive parameters of the model, with attention to the integrity of the elastic fibers, mechanosensing and mechanoregulation.

## Keywords :

Aortic aneurysms, Marfan syndrome, G&R model, hyperelastic model, microstructural parameters, finite element modeling, MATLAB, FEBIO

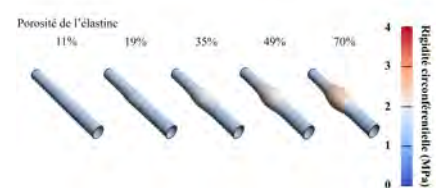

Visualization of the evolution of the aortic aneurysm in finite elements

Contact(s) : romain.gayraud@etu.umontpellier.fr



# End of study project:

## Optimization of welded joints for the transport of hydrogen gas

Sophiane HADDAR *MI*

Academic Supervisor : Laurent Waltz



### Objective / Motivation :

This end-of-study project is based on the study of the diffusion of hydrogen gas in steel and particularly on X80 steel and the effect of surface treatment processes as SMAT. Hydrogen might be a potential solution to the problem posed by fossil fuels. Indeed, this resource is renewable but poses a major problem, its transport. The goal of the project is to determine if the actual pipeline used for the transport of gas and fuel are suitable for the transport of hydrogen.

### Results :

Simulations have shown that hydrogen diffuses slowly into the material until a certain time when the regime becomes permanent and diffusion no longer evolves. Moreover, SMAT surface treatment is of real interest in reducing the rate of hydrogen diffusion. For the same simulation time, diffusion in a SMAT-treated material is much lower than in a non-SMAT-treated material. This means that SMAT treatment is a solution to hydrogen diffusion in X80.

### Keywords :

Matlab, 1D simulation, diffusion, hydrogen, hydrogen embrittlement, SMAT, surface treatment, microscope observation, weld bead

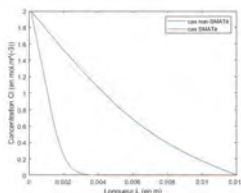

Hydrogen concentration in SMATed and non-SMATed materials for a simulation time of 40 000s

Contact(s) : [sophiane.haddar@etu.umontpellier.fr](mailto:sophiane.haddar@etu.umontpellier.fr)



# Integration of an articulated and servo-controlled foil system on a Nacra 17 / development of a flight simulator for the Nacra 17.



Arthur  
LAHOUSSE

Intégration d'un système de foils articulé et asservi sur un Nacra 17  
/ développement du simulateur de vol du nacra 17

Arthur LAHOUSSE *MI*

Academic Supervisor : Loic Daridon



NEOCEAN®

## Objective / Motivation :

Developing a flight simulator for the Nacra 17 (catamaran) with foil control to maintain the boat's altitude. Physical integration of the foils onto the boat.

## Results :

Development of the simulator on Matlab. Creation of a dynamic simulator with the boat's geometry and control input from Neoclean. Analysis of the obtained results and optimization of settings.

## Keywords :

Sail Boat Simulator Matlab

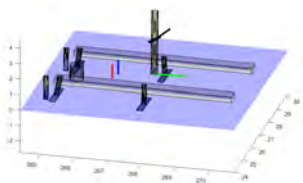

Geometry of the simulation

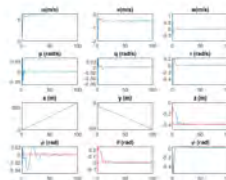

Results of the simulation

Contact(s) : arthur.lahousse@etu.umontpellier.fr



# Elastic anisotropy of aperiodic lattice structures

Measurement of the type and degree of anisotropy of "hat" tilings that can strictly aperiodically tile the plane



Antoine  
LARROQUE

Antoine LARROQUE *MI*

Academic Supervisor : Yann Monerie



## Objective / Motivation :

The aim of this study is to analyze the mechanical properties of einstein's aperiodic tiling based on the "hat" tile discovered in 2023, and in particular to determine its level and type of anisotropy. This analysis is carried out numerically on CAST3M using the finite element method.

## Results :

An anisotropy of  $\pi/3$  was found thanks to a parametric analysis on a Brazilian diametral compression test, and an anisotropy ratio of 0.8 was calculated using the norm ratio of the equivalent elasticity tensor of the structure and its projection on the basis of the isotropic tensors.

## Keywords :

aperiodic tiling tile hat ein stein anisotropy isotropy brazilian test homogenization cast3m FEM finite elements

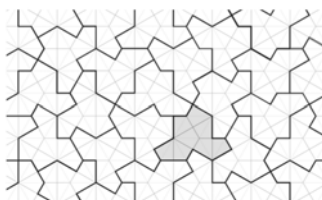

"Hat" tiling (object of the study)

Contact(s) : antoine.larroque@etu.umontpellier.fr

# Radômes and Composites Apprenticeship

contrat de professionnalisation



Léa  
LAVIGNE

Léa LAVIGNE *MI*

Academic Supervisor : Julien LAGET



# AIRBUS

## Objective / Motivation :

In the context of nose radomes and their multiple dimensions (materials, design, manufacturing processes, lightning resistance and transparency to radio waves, etc.), biblio/listing research and selection of potential materials of the future (bio-based resins, alternative non-conventional fibers).

## Results :

Drawing up mechanical and physico-chemical characterization test plans for monolithic and sandwich specimens, launch and follow-up of specimen manufacturing and exploitation of test results with the aim of anticipating design and/or stress impacts compared with the current design. Study of related subjects: watertightness of sandwich structures, influence of honeycomb compression meshes, automated honeycomb placement, simple microwave simulations, etc.

## Keywords :

radome aeronautics testing



*nose radome and radar antenna*

Contact(s) : [lea.lavigne@etu.umontpellier.fr](mailto:lea.lavigne@etu.umontpellier.fr)



# Design of a test bench for the treatment of cerebral aneurysm

Mechanical Engineering and Interactive Design



Ambre Manouviez

Ambre MANOUVRIEZ

Academic supervisors:

Franck NICLOUD



Stent Up

## Objective/Motivation:

Mechanical design a test bench to qualify and test, on site, devices developed for interventional neuroradiology, which imitates the hemodynamic of the human arterial network (i.e. presenting all or part of the arterial network as well as characteristic flows). This project involves the choice of components and materials, prototype management and condition testing, to respect budget and finally keep myself informed about new technology. First step is to design a compliance chamber for storing the incoming fluid and to propel it into the next component of the training device (i.e solenoid valve).

## Results:

COMSOL Multiphysics simulations were performed in order to find out the dimensions of the compliance chamber that satisfy requirements (pressure, flow). Thanks to this study, a compliance chamber will be printed in 3D and added to the test bench.

**Keywords:** R&D, test bench, aneurysm, COMSOL simulations

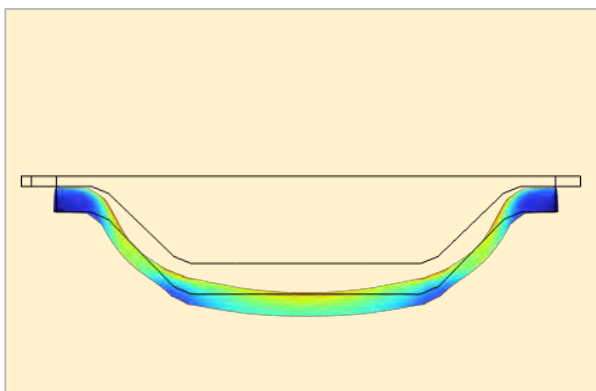

Example of 2D strain of the compliance chamber

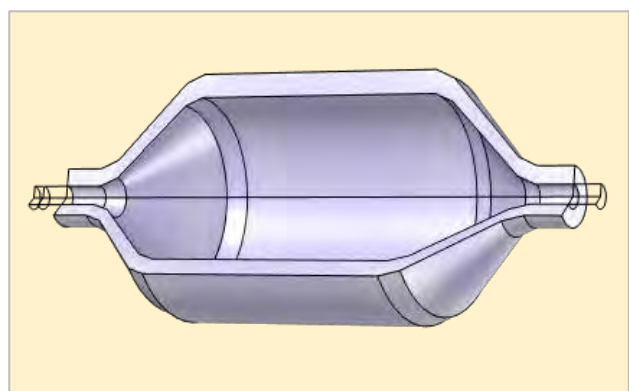

Compliance chamber COMSOL model 3D

Contact : [ambre.manouviez@etu.umontpellier.fr](mailto:ambre.manouviez@etu.umontpellier.fr)

# Finite element study of helicopter gearbox components



Lily  
MARINO

Study of a curvic coupling

Lily MARINO *MI*

Academic Supervisor : Yann Monerie



## Objective / Motivation :

The project is focused on the main gearbox of the Disruptive Lab, the new Airbus Helicopters prototype. The objective of the project is to study a curvic coupling, named with the French acronym R.A.D.I.C. The aim here is to carry out a fatigue analysis of the curvic, in parallel with bench testing. We want to test the real capabilities of this part, which is being implemented for the first time in the main gearbox of an Airbus Helicopters helicopter.

## Results :

The expected results are an estimate of the lifespan of this part. Ideally, its lifetime should confirm an infinite lifetime (in the case of the curvic > 20000h of flight).

## Keywords :

research & development - innovation - Mechanics - aerospace - Samcef/Altair

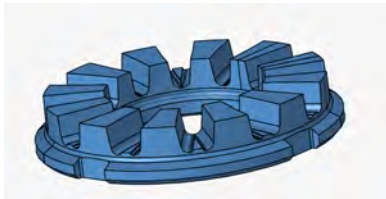

Curvic coupling studied for this project



Photo of the disruptive lab, a new prototype developed by Airbus.

Contact(s) : [lily.marino@etu.umontpellier.fr](mailto:lily.marino@etu.umontpellier.fr)



# Study of the strain of Nacra 17 sails' slats

Development of a flying controller for the Nacra 17 boat

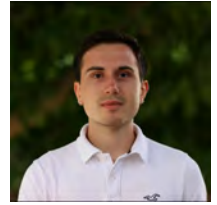

Pierre-Louis  
MARTIN

Pierre-Louis MARTIN *MI*

Academic Supervisor : Loïc DARIDON / Bertrand WATTRISSE



## Objective / Motivation :

This project aims at automatizing the navigation of Nacra 17 boats through the use of stereo-correlation. Equipping the boat with multiple cameras recording the sails would allow to measure 3D digital profiles of the sails through Digital Images Correlation (DIC). These profiles would then go through the MobulaSIM simulator to compute aerodynamic forces in the sails, and the navigation controller could deduct manoeuvres to perform to keep the boat flying (for maximum speed) in the right direction.

## Results :

3D digital profiles of various objects have been obtained through DIC training. Theoretical profiles were compared to numerical profiles to assess DIC and stereo-acquisition reliability. Unfortunately, it was not possible to perform sails measurements in due time, due to parts of the boat being stolen, making it impossible to attach the sails on the mast.

## Keywords :

Nacra17 Boat Nautical Race Digital Image Correlation Stereo Acquisition



*Nacra 17 boat flying : only the foils are immersed*

Contact(s) : pierre-louis.martin@etu.umontpellier.fr





# Hygroscopic swelling of Agrifoods

## White Beans deformations under water loading

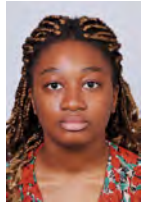

**Julie  
MVE NGUEMA**

**Julie MVE NGUEMA** *MI*

**Academic Supervisor : André Chrysochoos**



### Objective / Motivation :

This project focuses on the hygromechanical behavior of legumes, with white beans as a special case study. In addition to being a sustainable food source with a reduced environmental footprint, legumes are part of the growing trend towards plant-based diets and protein alternatives. The project presents a first numerical model taking into account hygroelastic couplings to estimate the stress levels that develop within the material during soaking. Knowledge of these stress concentrations is important for optimizing the cooking process.

### Results :

Once developed and implemented, the numerical model was used to simulate a soaking process. During soaking, water gradually penetrates the bean, creating gradients in water content. These gradients, in turn, induce stresses, the intensity of which depends directly on the material's hygro-dilatibility. The highest stress levels manifest as soon as soaking begins, near the surface of the bean, and are compressive in nature. As the bean uniformly soaks, these stresses gradually diminish.

### Keywords :

Stress, Deformation, Starch, Hygroscopic, Water, Food, Sustainable Development, Beans, Pulses, AgriFood, Elasticity

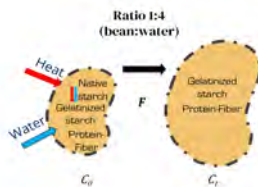

*Hydro-thermo-elastic coupling in the white bean*

**Contact(s) :** [julie.mve-nguema@etu.umontpellier.fr](mailto:julie.mve-nguema@etu.umontpellier.fr)



# Design and manufacture of an articulated finger using an elastomer dielectric actuator

Study and modeling of an elastomer dielectric actuator

Pierre PINON *MI*

Academic Supervisor : Bertrand Wattrisse



## Objective / Motivation :

The long term objective is to create a robotic finger that can be actionned using a dielectric elastomer actuator. This type of actuator has many benefits compared to rigid actuators, such as high precision and low energy consumption. This year , the main goals were to study, modelize and produce a dielectric elastomer actuator, which require various skills in mechanics, electronics and material science. This project is the fruit of the collaboration between the MI, MAT et MEA departments.

## Results :

The elastomer's mechanical behavior was modelled using the Yeoh model and the tests done on a few elastomer samples by Corentin Piot (MAT5). An optimisation program was then used alongside the test results in order to obtain the material parameters of the elastomer needed to simulate its behavior using the finite element method on Comsol. The mechanical model was proven accurate using the DEA prototypes made by Akram Benazzouz (MEA5) and the corresponding FEM simulation.

## Keywords :

FEM, Mechanics, Optimisation, DEA

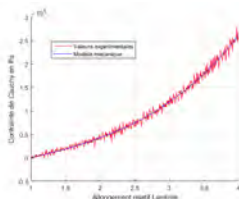

Comparison between the tests results and the mechanical model of the elastomer.



Experimental setup used to observe the displacements produced by the DEA prototype when tension is applied.

Contact(s) : pierre.pinon@etu.umontpellier.fr



# Statistical methods for rapid prediction of crack paths in concrete



Nicolas  
RABOT

Spatial range research in approaches for rapid prediction of cracking paths in concrete

Nicolas RABOT *MI*

Academic Supervisor : Yann Monerie / Alexandre Pinlou



## Objective / Motivation :

Cracking is a major issue for the lifespan of industrial installations, as it weakens the mechanical properties and tightness of these materials. Predicting the trajectories of cracks is of significant interest to enhance the lifespan of these structures. In order to improve statistical methods, the concept of "locality" is introduced to consider nearby weak areas relative to the current point of the concrete.

## Results :

Two progression units are studied to implement the detection distance: a numerical unit based on graph depth and a physical unit based on progression within the matrix. The transition between a local and a global method is observed, depending on the detection distance. This transition depends on the shape and progression method within the matrix, but further studies on other parameters could be interesting.

## Keywords :

Python ; Concrete ; Cracking prediction ; Detection distance ; Weak areas

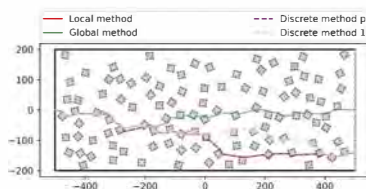

Cracking path for different methods with a detection distance equivalent to a graph depth  $p = 10$

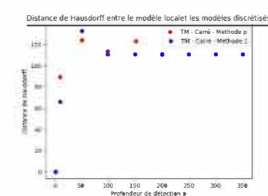

Transition from a local method to a global method of cracking path depending on the depth of the graph

Contact(s) : nicolas.rabot@etu.umnotpellier.fr



# Mechanical design

## Parts design for a hybridization system



Sacha  
THOMANN

Sacha THOMANN *MI*

Academic Supervisor : Aurélie MARCHAL



### Objective / Motivation :

The aim of this project is to design parts enabling the addition of a hybridization system to the main gearbox of a helicopter engine.

### Results :

For the moment I just trained myself on the different software used, and realized different lubrication test. First, I will design few solutions on CATIA, then I will organize design review. After one of these solution is validated, i will design a test bench, to test prototype of the solution.

### Keywords :

Design, part, aeronautics, test, CATIA, helicopters

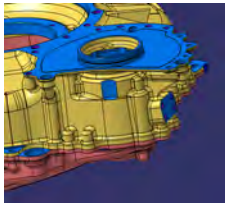

Hybridization crankcase made on CATIA



Disruptive Lab

Contact(s) : [sacha.thomann@etu.umontpellier.fr](mailto:sacha.thomann@etu.umontpellier.fr)



# Fatigue Sizing of a Gear in the Main Transmission Box of a Helicopter

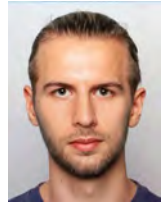

Nathan  
TRAVERS

Preparation of calculation notes for the client Airbus Helicopters

Nathan TRAVERS *MI*

Academic Supervisor : MONERIE Yann / DESTAILLEURS Florent



## Objective / Motivation :

Fatigue corresponds to the progressive degradation of the mechanical properties of a material under the effect of cyclic, repeated, or alternating loads. Within rotating systems or those subjected to this type of solicitation, it is important to take them into account to avoid an accident caused by the rupture of a system component. The objective of this professionalization contract is to guarantee the durability of various components of a helicopter to a minimum number of cycles based on a finite element mechanical simulation.

## Results :

The finite element mechanical simulation allows evaluating the stress state and the type of loading that a part undergoes during its use. This simulation ensures that the part is capable of withstanding the loads applied to it statically, for example by dimensioning within its elastic domain, but also in fatigue, using a Wohler diagram. In the event that the component does not meet the sizing criteria, its geometry, composition, or the safety factors used will need to be reconsidered.

## Keywords :

Finite element method / Material fatigue / Helicopters

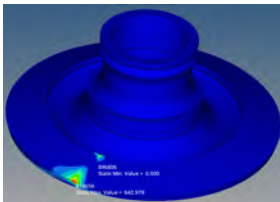

Finite element numerical simulation of a helicopter gear

Contact(s) : [nathan.travers@etu.umontpellier.fr](mailto:nathan.travers@etu.umontpellier.fr)



# Sizing and calculation of metal frames.

Creation of a reinforced photovoltaic range.



Gauthier  
VALLEE

Gauthier VALLEE *MI*

Academic Supervisor : Ollier Clément



## Objective / Motivation :

The objective is to create a new range of buildings, more resistant, which makes it possible to increase the length of spans and to resist photovoltaic overload.

## Results :

Reinforcing structures often involves adding struts, increasing the thickness of the tubes and changing the sections or grade of the steel. We must pay attention to the additional cost generated by these modifications, by trying to create buildings that are as inexpensive as possible but which resist the load.

## Keywords :

Calculation of structures, metal frames, AutoDesk

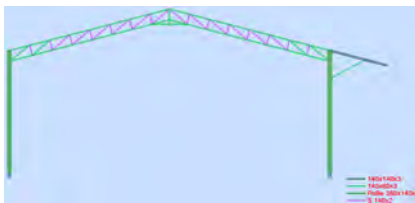

Standard structure profile.

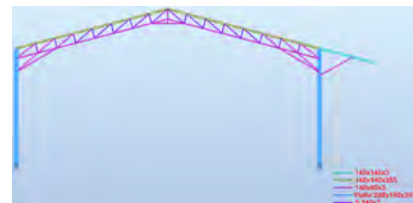

Reinforced structure profile.

Contact(s) : [gauthier.vallee@etu.umontpellier.fr](mailto:gauthier.vallee@etu.umontpellier.fr)









# Transport crates for control cluster mechanisms

From engineering and design to drawing and fabrication

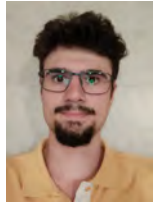

Cédric  
BRUN

Cédric BRUN *MSI*

Academic Supervisor : Jean-Michel Muracciole



# SIGEDI

## Objective / Motivation :

The objective of this project is to engineer and design three transport crates for radioactive/contaminated mechanisms, adhering to strict specifications while making those crates easy to use and affordable.

## Results :

The crates are constructed almost entirely from stainless steel. They measure 5400x1800 mm and stand 785 mm tall. They weigh 1700 kg when empty and 4300 kg when fully loaded. In non-SI units, this translates to 17.7x5.9 ft with a height of 2.6 ft. For 3750 lb empty and 9480 lb fully loaded.

## Keywords :

Steel ; Stainless steel ; Sheetmetal ; Nuclear industry ; Safety ; Engineering ; design ; Boildermaking ; Mechanical ; 3D Modeling



*Exploded view*



*Closed crate with forklift*

Contact(s) : [cedric.brun@etu.umontpellier.fr](mailto:cedric.brun@etu.umontpellier.fr)



# Improving the reliability and quality of agricultural hangar offers

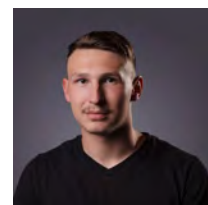

Maxime  
CHEVRON

In terms of structure-related issues

Maxime CHEVRON *MSI*

Academic Supervisor : Fabien SOULIE



## Objective / Motivation :

The construction of farm buildings and the installation of solar panel power plants accounts for 70% of Arkolia's business. Before I started my apprenticeship, no one was addressing the structural issues. The initial aim was to set up a structural engineering branch. Furthermore, we had to create dimensioning databases, technical monitoring, and optimization of steel structures to improve the standard buildings offered by Arkolia.

## Results :

The structure division has carved out a place for itself. It provided both expertise and technical oversight in its domain. Several resources and databases are now available, in-house teams are now trained to use them. The offers for standard agricultural sheds have been modified and the costing of the buildings is more accurate because it depends mainly on the design and scientific studies. The business/purchasing departments have a more accurate cost assessment which enhances the company's competitiveness in the renewable energy market.

## Keywords :

#Resistance of materials #Corrosion #Standards #Eurocodes #Costing #Mounting systems for solar panels #Team training #Surface treatment

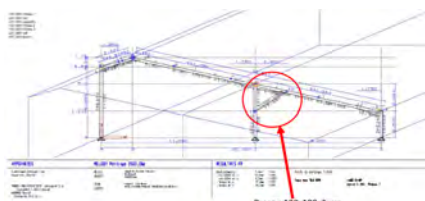

Reinforcing and optimising profile sections using strutting



Team training of design and costing tool

Contact(s) : maxime.chevron@etu.umontpellier.fr



# Replacement of a bundle from an overdryer heater generator (GSS)

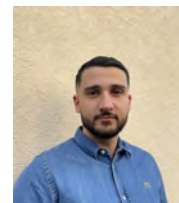

Mounir  
DJERROUD

On the unit 3 of the Cruas-Meysses nuclear power plant

Mounir DJERROUD *MSI*

Academic Supervisor : Denis CERVELLIN



## Objective / Motivation :

During the inspection of the Cruas 3 unit, defects were identified on a overheater dryer generator. In response to these findings, the client decided to replace this bundle at Cruas 3 unit in 2024. ALTRAD ENDEL, an expert in GSS-related work, was selected to carry out this replacement operation. On this project, I was responsible for the methods and welding aspects, with my main tasks including the definition of the regulatory framework, the on-site monitoring of the technical aspects and the managing of deviations.

## Results :

Since the equipment has only one movable bottom, it's necessary to first extract the 3 GSS 004 ZF bundle to remove the 3 GSS 002 ZF bundle for replacement, followed by reinserting the 3 GSS 004 ZF bundle. This operation involves extensive cutting, connecting, handling, lifting, machining, and mechanical work. The work is ongoing and is expected to be completed by mid-October 2024. We have already removed the two bundles and are currently installing the new bundle. Everything has proceeded smoothly, with meticulous management at every stages.

## Keywords :

Nuclear power plant - Pressure vessel - Regulations - ISO standards - CODAP - Project follow-up - Lifting - Handling - Welding



Receipt of new bundle 3 GSS 002 ZF



Extraction of a bundle from the GSS shell

Contact(s) : [mounir.djerroud@etu.umontpellier.fr](mailto:mounir.djerroud@etu.umontpellier.fr)



# Supplier Surveillance Plan Optimization

Automatization and Standardization of the Process



Valentin  
DUPORT

Valentin DUPORT *MSI*

Academic Supervisor : Denis CERVELLIN



## Objective / Motivation :

Since the merger of the Airbus and Safran space divisions to form ArianeGroup, the various Supplier Quality teams have kept their own operating methods. It was therefore necessary to standardize and to automatize practices. The objective was to create a tool to centralize the data, automatize the Surveillance Plan process and to be able to track the actions performed. The goal of this project is to divide by 4 the time spent establishing the surveillance plan for each of the 800 suppliers, from 2 hours to 30 minutes.

## Results :

A working group was set up for this project, made up of several departments in France and Germany, and together we defined a process to meet the needs of all teams. After collecting the data from the different ERPs, we were able to centralize it in the new intelligent database. This level must only be validated by the manager, then defines the actions to be performed. These actions are automatically managed in the new action tracking system. The estimated gain from this project is €155,000 per year thanks to the time saved.

## Keywords :

Quality 4.0 - Project Management - Supplier Quality - Surveillance Plan - Process Automatization - Agile - Lean - 6-Sigma



Automatic data processing diagram of the new tool



Detail of the evolutions implemented by the new process

Contact(s) : valentin.duport@etu.umontpellier.fr



# Pipelines and metal structures design using 3D scanner technology



Janis  
FRANCAVILLA

PAC project for VALBOM and DAPSOL project for  
ARCELORMITTAL

Janis FRANCAVILLA *MSI*

Academic Supervisor : Fabien SOULIE



## Objective / Motivation :

VALBOM project: The objective of this project was to create a new unit aimed at improving the energy efficiency of the Energy Recovery Units located in Bègles. To achieve this, two heat pumps were purchased. The goal was to connect these heat pumps to various existing nearby equipment. DAPSOL project: For this project, the objective was to replace existing pipelines used to transport powdered minerals. A new design was necessary to prevent the clogging of powders, an issue that the client had with their original installation.

## Results :

VALBOM Project : We created a 3D model of the installation and connections to the existing equipment using 3D scans. Then, we produced isometric drawings for over 450 meters of piping for the contractor. There were no unforeseen issues on the site regarding the piping. DAPSOL Project : We created a 3D model proposing a new layout for the piping. We prepared preliminary piping and support blueprints for the client, who recently approved the project internally. The fabrication will begin soon.

## Keywords :

3D Modeling / 2D Blueprints / Customer communication / Project monitoring / Information management

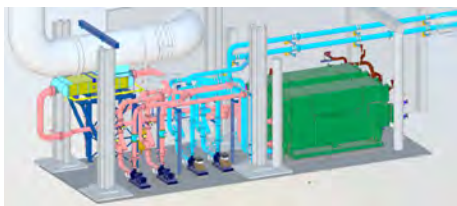

3D model of VALBOM project

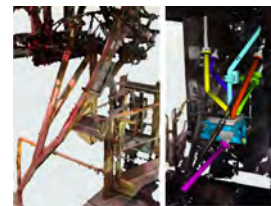

3D model of the DAPSOL project (old design on the left and new design on the right)

Contact(s) : [janis.francavilla@etu.umontpellier.fr](mailto:janis.francavilla@etu.umontpellier.fr)



# Development and qualification of a storage container (CID)



Quentin  
GIACALONE

Phasing and technical development for qualification testing

Quentin GIACALONE *MSI*

Academic Supervisor : Jean-marc BENOIT



## Objective / Motivation :

The aim is to carry out studies to check the accuracy of the theoretical design. Manufacture test prototypes. Qualify the package and have a benchmark solution for storing waste.

## Results :

To date we have manufactured the pre-series and the associated qualification testing is in progress.

## Keywords :

Container, Stainless Steel, Nuclear waste, Technical Study, Qualification, Project management

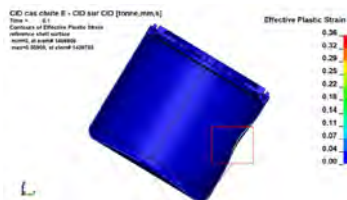

Pre-industrial process



Production series and qualification

Contact(s) : [quentin.giacalone@etu.umontpellier.fr](mailto:quentin.giacalone@etu.umontpellier.fr)



# Onboard Unloading Dock

Safety work on board truck trailer

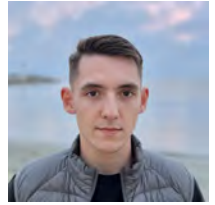

Louis  
GILLES

Louis GILLES *MSI*

Academic Supervisor : Martine CAMBON



## Objective / Motivation :

The objectives of the project are design, sizing and manufacturing follow-up of equipment for securing access to truck trailers during loading and unloading operations.

## Results :

An Onboard Unloading Dock on truck trailers has been developed. This first dock will maximize its utility, with the aim of becoming a standard and being required on our construction sites.

## Keywords :

Innovation, Safety, Tool, Onboard, Truck, Trailer, Ampliroll, Unloading, Construction site, Industry



*The device is folded in the dock for the transport.*



*The device is unfolded from the dock for securing access.*

Contact(s) : louis.gilles@etu.umontpellier.fr



# Design and manufacture of a level 2 Nuclear Pressure Equipment



Valérian  
GUILLAUD

Exhaust Silencers for FA3 nuclear power plant

Valérian GUILLAUD *MSI*

Academic Supervisor : Fabien SOULIE



## Objective / Motivation :

The objective was to design and manufacture a level 2 Nuclear Pressure Equipment within a very short time frame of three months. This timeline was tight due to the urgent need to replace equipment at the Flamanville nuclear power plant. A nozzle on one of the pieces of equipment had ruptured due to fatigue. This equipment is a silencer that reduces pressure pulsations generated by the blower, thereby lowering the sound level.

## Results :

Numerous meetings were held between the manufacturer (ACM), the operator (EDF) and the control body (APAVE) in order to move the project as quickly as possible in view of the urgency of the project. Many solutions have been implemented such as revamping a silencer from another project and updating the design to reduce vibration risks. In the end, the challenge was successful since the equipment was delivered on time. This project was very interesting and allowed me to use my technical and theoretical knowledge acquired during these three years.

## Keywords :

Nuclear Pressure Equipment - Welding - Regulations - Boilermaking - Nuclear power plant - Engineering - Repair - Project management



*Piquage having undergone a rupture by vibratory phenomenon*



*Exhaust Silencers for FA3 manufactured by ACM*

Contact(s) : [valerian.guillaud@etu.umontpellier.fr](mailto:valerian.guillaud@etu.umontpellier.fr)





# Setting up a support service for NDT Engineering

To save time on our jobsites and be self-sufficient

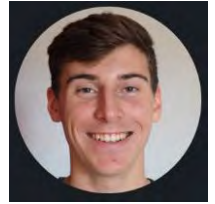

Evan IDELON

Evan IDELON *MSI*

Academic Supervisor: Aurelie Marchal



## Objective / Motivation:

The objective is to create a team with technical documents that can be autonomous in a field of Non-destructive testing engineering. Because currently, we can't do this part in reason of your knowledges and our effective. The consequences of this lack, that we lose lot of time in our missions (+100 days at the nuclear power plant of Saint Alban).

## Results:

Today, this team is up and running, and has proved his performance on different jobsites (Bugey/Cruas/Flamanville) where we have aligned the reality with our forecasts. The next step is to increase our workforce.

## Keywords:

- Innovation
- Skill enhancement
- New project
- Job creation
- Creating Technical documents
- Optimization



*Before innovation*



*After innovation*

Contact(s): [evan.idelon@etu.umontpellier.fr](mailto:evan.idelon@etu.umontpellier.fr)

# Improvement of the Fire Extinguishing System for 10 Transformers - CEA Marcoule

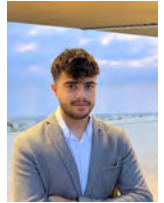

Louka  
LACROIX

Piping project at a nuclear site aimed at improving the safety and efficiency of an existing extinguishing system

Louka LACROIX *MSI*

Academic Supervisor : Jean-Marc BENOIT



FOURÉ  
LAGADEC

A COMPANY OF GROUPE SNEF

## Objective / Motivation :

The objective of this project is to strengthen the safety and efficiency of the aging facilities of the 'SAG' installation at CEA Marcoule. This project will enable the Local Security Team at CEA Marcoule to intervene in case of a fire affecting one or more of the 10 High Voltage transformers, through a piping system that will allow for effective and safe fire extinguishing.

## Results :

Each section of piping has been fabricated, welded, and installed around each transformer. The tests have validated the compliance of all the fire extinguishing piping, allowing CEA to benefit from optimal protection for its transformers.

## Keywords :

Specifications analysis - Cost estimation - Technical and Financial proposal - Project management - Planning - Technical study - Technical documents - Safety - Piping - Extinguishing – Nuclear



*Initial extinguishing system, operating with pressurized water from the tank to the extinguishing lines around the transformer.*

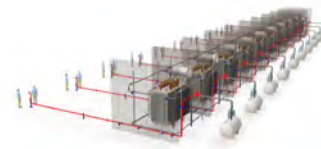

*Improvement of the initial system by adding piping with quick-connect firefighter couplings for effective and safe extinguishing (red pipe).*

Contact(s) : louka.lacroix@etu.umontpellier.fr



# Welding project management

## SEK piping replacement at CRUAS nuclear power plant



Débora  
LAGRANGE

Débora LAGRANGE *MSI*

Academic Supervisor : Aurelie Marchal



### Objective / Motivation :

The project's goal is to execute a three-year replacement of 1.5 kilometers of the SEK network at the Cruas nuclear plant. Key responsibilities include designing technical solutions, creating a precise schedule, developing a tracking tool, managing finances, and coordinating teams. This project offers a unique opportunity to acquire essential skills and demonstrate the role of an engineer in a challenging, real-world environment.

### Results :

This project has allowed me to work on various aspects and overcome challenges by finding appropriate solutions. Although the project is still ongoing, we have managed to progress despite the obstacles encountered. However, due to various issues on both our side and EDF's, the initial deadline will not be met. Nevertheless, this project has been an enriching experience, providing valuable challenges for my professional growth.

### Keywords :

Piping, welding, nuclear power plant, monitoring tool, team management, financial, coordination, SEK

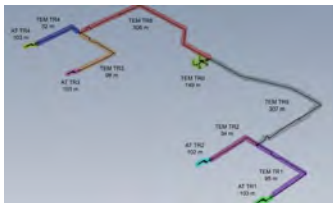

3D pipe model



Picture of a section of SEK piping in the gallery

Contact(s) : [debora.lagrange@etu.umontpellier.fr](mailto:debora.lagrange@etu.umontpellier.fr)



# Production launch of a new product

Factory Development



Alexandre  
MARINI

Alexandre MARINI *MSI*

Academic Supervisor : Andrea PIARRESTEGUY



## SHERCO

### Objective / Motivation :

Facelate the transition between the research and development department and the production department. Adapt technical documents and tools to the new generation of motorbikes is accessible to any qualified operator. Ensure that the assembly process is accessible to any qualified operator for each product subassembly.

### Results :

Conformity of the manufacturing process. Creation of a technical database and quality products. Ensure that data packages are complete and readily accessible. Prepared for mass production. Quality control measures are in place and functioning effectively. Each version of the new generation is available in the workshop.

### Keywords :

Motorcycle, Technical documents, Custom-made tools, Computer-aided design, Industry, Stopwatch analysis, Work zone development, Process reliability



New 2025 motorbike



New 4 stroke engine

Contact(s) : alexandre.marini@etu.umontpellier.fr



# Development of Custom Tooling for Anti-Corrosion Coating of Industrial Valves with Cooling Envelopes

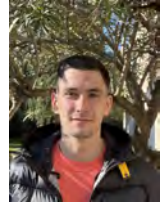

Romain  
MONNIER

Innovative Filling Techniques and Specialized Equipment Design  
for Optimal Coating Application

Romain MONNIER *MSI*

Academic Supervisor : Fabien SOULIE



## Objective / Motivation :

The objective of this project is to design and develop specialized tooling for the anti-corrosion treatment of industrial valves with cooling envelopes. These structures present unique challenges for coating application, as traditional methods are insufficient for ensuring complete coverage in hard-to-reach areas. This project focuses on creating a custom solution that enables effective coating through a filling process, ensuring all internal surfaces within the cooling envelopes are adequately protected.

## Results :

The project has resulted in the design and fabrication of an innovative tooling system that facilitates the filling and draining process required for applying anti-corrosion coatings to valves with cooling envelopes. This equipment ensures that the protective coatings are uniformly distributed within the complex internal chambers, addressing areas that were previously inaccessible using conventional methods. The new process significantly enhances the longevity and reliability of the valves in corrosive environments.

## Keywords :

Cooling Envelopes, Anti-Corrosion, Custom Tooling, Filling Technique, Industrial Valves, Coating Application

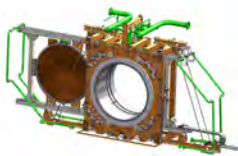

Overall view of the industrial valve with integrated cooling envelope.



Custom-designed testing tooling for the uniform application of anti-corrosion treatments inside the cooling envelopes.

Contact(s) : [romain.monnier01@etu.umontpellier.fr](mailto:romain.monnier01@etu.umontpellier.fr)



# Design of an LDPE production plant at

TECHNIP ENERGIES

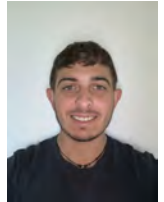

David  
NOUET

David NOUET *MSI*

Academic Supervisor : Philippe PAPET



## Objective / Motivation :

The primary goal of this project was to gain hands-on experience with high-pressure systems at Technip Energies. To achieve this, I worked on a study of an LDPE production plant. Lyon operating center has been involved in LDPE plant projects since 1967, having built 23 plants between 1967 and 1986 in countries such as India, Portugal, Croatia, Brazil, France, and Spain. This report will describe the operation of an LDPE production plant and the tasks assigned to me during the Ningmei project.

## Results :

This report is divided into three sections. The first section introduces the company where I completed my internship and outlines the deliverables of a typical project. The second part talk about the concept of high pressure at Technip Energies, using the Ningmei Sabic LDPE production plant as a case study. Finally, to complete this report, I present a common task within our department: revamping pressure vessels. The role of an engineer at Technip Energies requires strong interpersonal skills as it involves constant interaction with colleague.

## Keywords :

Technip Energies, Engineering, LDPE, Pressure vessels



LDPE production plant



Rupture disc

Contact(s) : david.nouet@etu.umontpellier.fr



# Project "ETHER"

An art project: from conception to completion

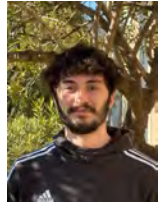

Flavien  
ROUX

Flavien ROUX *MSI*

Academic Supervisor : Philippe PAPET



## Objective / Motivation :

The project aimed to design and build Kohei Nawa's "Ether," a 25-meter-tall sculpture symbolizing equality through a droplet. Our motivation, including my own, stemmed from the challenge of applying our skills to a completely different field the world of art and from the opportunity to be part of Seguin Island's cultural landscape.

## Results :

The project successfully delivered a captivating art piece. Throughout the process, various challenges were overcome. The final product met all specified requirements and received positive feedback from both the artist and the team, showcasing the effective collaboration between engineering and artistic disciplines.

## Keywords :

Art - Design - Drawing - Manufacturing - Welding - Machining - Project management - Assembly - Materials - Planning - Optimisation - Rigidity - Problem solving - Fabrication



*ETHER production in our workshop*



*ETHER on its launch day in Paris at Île Seguin*

Contact(s) : [flavien.roux@etu.umontpellier.fr](mailto:flavien.roux@etu.umontpellier.fr)



# Qualification of a hard brazing machine

With a view to integration into the production line



Maxime  
VERTUT

Maxime VERTUT *MSI*

Academic Supervisor : Denis CERVELLIN



## Objective / Motivation :

The objective is to qualify a resistance brazing machine to restart production following the replacement of the previous one. This includes setup testing, operator training, and updating the related process documentation.

## Results :

The qualification is still ongoing today because several references are involved, but for a certain part, production has already been restarted.

## Keywords :

resistance brazing, production, setup testing, process documentation, qualification



*Brazing machine to qualify (only the command box have been changed)*



*one of the parts involved for brazing*

Contact(s) : maxime.vertut@etu.umontpellier.fr





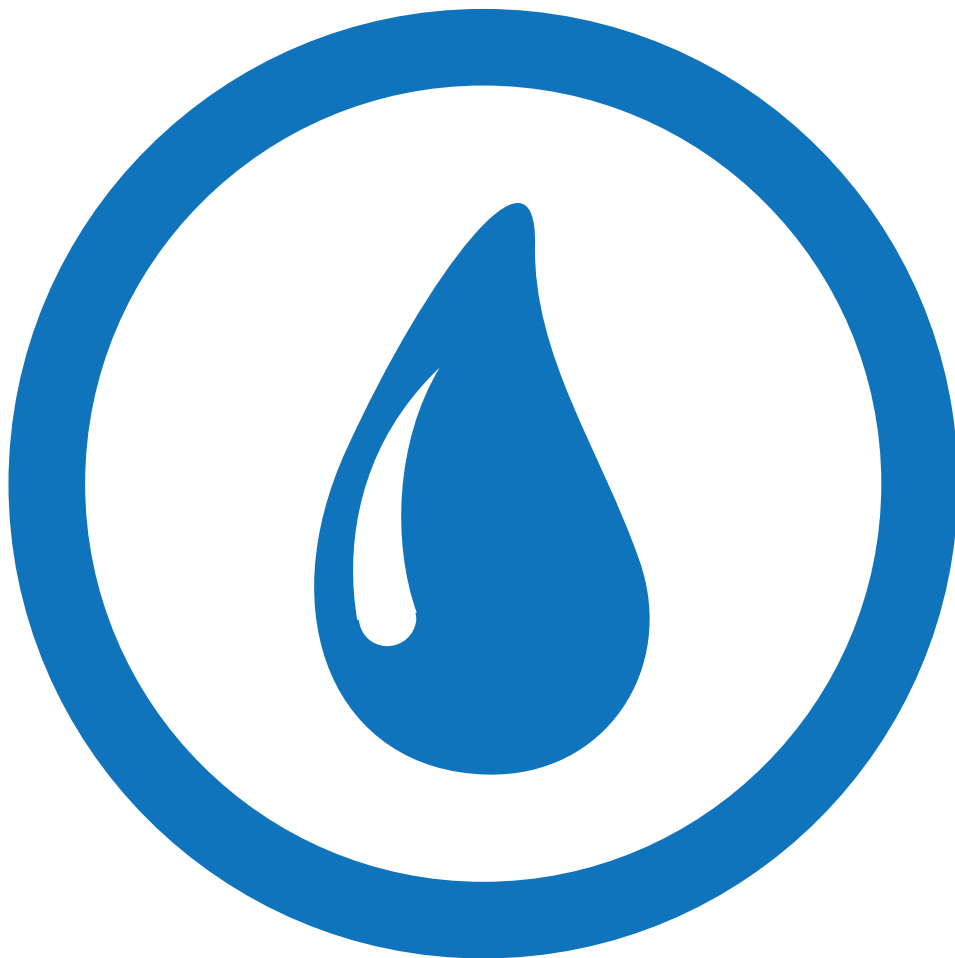

# Study of water quality of community of municipalities of Argonne Champenoise



Mohammed  
BENCHAIIB

caracterization of drinking water drilling concerning the impact of pesticides on them

Mohammed BENCHAIIB *STE*

Academic Supervisor : Julie MENDRET



## Objective / Motivation :

As part of the engineering cycle in Water Sciences and Technologies at the Ecole Polytechnique de Montpellier, I joined a company for my last year as an alternation in professional contract. From October 30 to January 12 of 2023, I was commissioned within the company Génie de l'Eau, to perform various tasks concerning the quality of water intended for human consumption. This report summarizes briefly one of them, which is the study of the presence of pesticides in the network of the community of communes of Argonne Champenoise (CCAC).

## Results :

In conclusion, the study carried out on the presence of pesticides in the CCAC's drinking water boreholes revealed the non-compliance of several of them. CCAC's drinking water wells has highlighted the non-compliance of several of them. In all, more than more than 40% of drilling showed pesticide concentrations in excess of the quality limit. Two molecules were responsible for more than 80% of exceedences of quality limits : chloridazone désphényl and chloridazone méthyl désphényl.

## Keywords :

pesticide water quality chloridazone quality limit drilling boreholes



Caractérisation of each drilling

Caractérisation	Zone nord	Zone centre	Zone sud	Total
Forage non exploité	0	2 (7%)	0	2
Aucune détection de pesticides	6 (75%)	7 (25%)	1 (9%)	14
Au moins une détection sans dépassement de LQ	1 (12,5%)	8 (29%)	3 (27%)	12
Au moins un dépassement de la LQ	1 (12,5%)	11 (40%)	7 (64%)	19
<b>Total</b>	<b>8</b>	<b>28</b>	<b>11</b>	<b>47</b>

summary of results

Contact(s) : mohammed.benchaib@etu.umontpellier.fr



# Ecological monitoring of a river

## Macro invertebrate indexes



Margot  
CIBOT

Margot CIBOT *STE*

Academic Supervisor : **Chrystelle Montigny**



### Objective / Motivation :

In response to the new assessment rules set by the Water Framework Directive, an improvement of bio-indication methods based on macro-invertebrate observation has been achieved. Thus, the new I2M2 index makes it possible to better assess the ecological state of a watercourse, but also to detect pressures related to human activities. This subject is about results of hydrobiological analyses (I2M2 and EQR IBG) of a stream monitoring in order to assess the impact of a groundwater polluted by a petrochemical company on the nearby stream.

### Results :

Indices indicate that the watercourse is in good ecological condition, in compliance with the Water Framework Directive. However, we note that the downstream station has some weaknesses (not serious)

### Keywords :

Ecology Indices Hydrobiology



Poster PFE: presentation of the subject

Contact(s) : [margot.cibot@etu.umontpellier.fr](mailto:margot.cibot@etu.umontpellier.fr)



# Upgrading of hydraulic structures in the city of Gignac



Matar  
DRAMÉ

How a storm overflow works

Matar DRAMÉ STE

Academic Supervisor : Vincent Guinot



## Objective / Motivation :

In the context of increasing the capacity of the wastewater treatment plant, the city of Gignac has a functional sewer system that occasionally does not comply with environmental quality guidelines. Indeed, frequent discharges into the Hérault River, exceeding the regulatory limit of 20 per year, have been observed. To comply with state authorities' requirements, the municipality must address these issues before starting the planned construction work.

## Results :

The study aims to bring a storm overflow in Gignac into compliance. The lack of information in certain areas hinders the complete resolution of the overflow issue. Intermediate solutions, such as installing flow monitoring instruments, are considered to gather the missing data. Recommendations for adjustments to hydraulic structures are proposed to facilitate the ongoing study towards a definitive resolution of the problem.

## Keywords :

Storm overflow: A hydraulic structure designed for the combined evacuation of wastewater and rainwater. Water is sent either to the treatment plant or to the natural environment, depending on the water level in the structure.



Networks and structures in the study area

Contact(s) : [matar.drame@etu.umontpellier.fr](mailto:matar.drame@etu.umontpellier.fr)



# First professional module in Degrémont France, subsidiary of Suez



Emma  
FANTON

Discovering of the technical studies engineer's profession

Emma FANTON *STE*

Academic Supervisor : Marc HERAN



## Objective / Motivation :

The first 10 week professional unit started with Degrémont France in Strasbourg as a technical studies engineer (IRET) student-apprentice working in the engineering bureau. The first goal was to understand the inner workings of the company through the discovery of its many departments. The integration process allowed for a better understanding of the part played by the IRET and their criticality in the company. Then, a selection of the IRET's tools and skills were learned and practiced thanks to the tasks completed during this unit.

## Results :

During these ten weeks in the company, I dealt with many little tasks (working on Machine Directive, filling of technical specifications...) and I did not worked on a big project. That is the reason why there are no results to expose here.

## Keywords :

Water treatment plant, technical specification, risk analysis, Safety and Health at Work



Assembly of lamellar modules during the visit to the Laon's water treatment plant

Contact(s) : emma.fanton@etu.umontpellier.fr



# STEP de Claira

Etude de faisabilité : STEP de Claira



**Mathis  
FLEURANT**

**Mathis FLEURANT** *STE*

Academic Supervisor : **Stéphan Brosillon**



## Objective / Motivation :

The city of Claira should experience an increase in its population according to urban planification and INSEE. The feasibility study consists of knowing the future loads of the Claira STEP. The objective is to find suitable solutions and see what arrangements will be necessary for future polluting and hydraulic loads.

## Results :

Future hydraulic loads will be too high in rainy weather. A storm basin will therefore be added for excessive flow rates. Future loads will be too high from a polluting point of view, for this it is necessary to add an anoxic basin. It is also necessary to change the screening and UV treatment.

## Keywords :

waste water treatment plant, hydraulic, polluting,



*Water Clarifier in Claira*

Contact(s) : [mathis.fleurant@etu.umontpellier](mailto:mathis.fleurant@etu.umontpellier)



# Protocols for oxygenation of a wetlands for wastewater treatment



Jourdain program

Samia  
GOUBERT

Samia GOUBERT *STE*

Academic Supervisor : Julie Mendret



## Objective / Motivation :

This PFE outlines the reoxygenation protocols implemented, for a refined water in a wetland. Two structures are examined: oxygenating cascades and aerated basins using fine bubble diffusers. Various variables (water flow rate, airflow rate, cascade profile, and water level in the basins) are altered to determine their effects on the oxygenation efficiency of the structures.

## Results :

According to the literature searches carried out upstream, the oxygenation produced by a cascade in steps is mainly influenced by the water supply flow because it modifies the water flow regime. Concerning the injection of fine air bubbles in the forced aeration tanks, the water height above the diffusers, the water flow and the air flow are the parameters that have the greatest impact on the oxygenation performance.

## Keywords :

Wetlands for wastewater treatment, oxygenation, cascades, fine bubble pipes



*PFE poster on the oxygenation of a wetland for wastewater treatment - Jourdain program*

Contact(s) : samia.goubert@etu.umontpellier.fr



# Rainwater management master plan for the town of Treilles

Pierre GUIBOUX *STE*

Academic Supervisor : Pascal FINAUD-GUYOT



## Objective / Motivation :

The aim of this report is to provide a complete study of the initial phase of a stormwater management master plan. The purpose of the stormwater management master plan is to provide the municipality with a strategy for combining urban development with protection of the receiving environment. This study considers several factors in the area analysed, the main aim of which is to determine any malfunctions and shortcomings in the municipality's stormwater network and to suggest improvements and solutions for stormwater management.

## Results :

The initial phase of describing the current situation and the phase of modelling the hydraulic functioning of the municipality was dealt in this project. The final outlet for rainwater in the commune of Treilles is the Salses-Leucate lake. The pond is in good ecological and chemical condition, and the village of Treilles should not have any impact on the quality of this water. 14 outfalls, 2 retention basins and 83 swallowing devices were identified in the study area. The 100-year rainfall does not cause any overflows in the collection network.

## Keywords :

rainwater, the stormwater management master plan, strategy, stormwater network, Treilles, water quality



Map showing the location of Treilles in the Great Narbonne area



Results of a 100-year rainfall on the commune of Treilles with PCSWMM

Contact(s) : pierre.guiboux@etu.umontpellier.fr





# Study of the operation of a membrane contactor for the agronomic recovery of nitrogen



Clémentine  
LABET

Clémentine LABET *STE*

Academic Supervisor : Marc Héran



## Objective / Motivation :

Only a small proportion of the nutrients arriving at the water treatment plant are recycled. By separating and collecting urine at source, it would be possible to recycle the nitrogen it contains. The aim of this project is to demonstrate that it is possible to reclaim human urine. The aim is therefore to study technological solutions for recovering the nitrogen it contains to produce biosourced fertilizer. More specifically, to study the operation of a membrane contactor used for  $\text{NH}_3$  gas/liquid transfer.

## Results :

The membrane contactor used was characterized, and the liquid entry pressure was determined. We set up an experimental pilot to measure the  $\text{NH}_3$  flux transferred through the membrane contactor. To study the transfer, tests were carried out by varying the flow rates of the gas and liquid, thus modifying the hydraulic regime on either side of the membrane. Co-current and counter-current fluid flow were tested, and transfer coefficients were determined by monitoring solution pH.

## Keywords :

Membrane contactor, nitrogen, mass transfer, urine reclamation

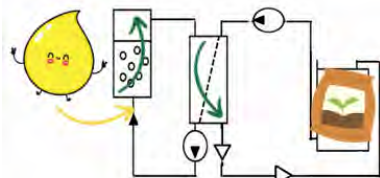

Process for recovering nitrogen from urine

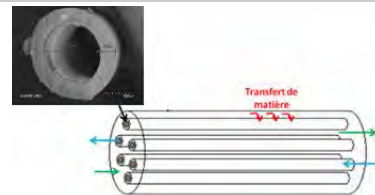

Mass transfer in the membrane contactor

Contact(s) : [clementine.labet@etu.umontpellier.fr](mailto:clementine.labet@etu.umontpellier.fr)



# Preparation of the Water Law Document and hydraulic studies for the upcoming creation of a Joint Development Zone.



**Romain  
MARVY**

"Les Espassoles" Joint Development Zone in Thuir (66)

**Romain MARVY** STE

Academic Supervisor : **Christian SALLES**



## Objective / Motivation :

Conducting hydraulic studies to produce a Water Law Declaration File is necessary for the future establishment of a "Les Espassoles" Joint Development Zone in the municipality of Thuir (66). These hydraulic studies involve assessing the current hydraulic situation in the project area and sizing hydraulic structures, because of the soil sealing of the project area, like retention basins and stormwater collection networks, adhering to specific design criteria.

## Results :

The hydraulic functioning of the project area was identified using topographical data, land use information, and existing stormwater networks, enabling the definition of watersheds within the study area. This data was integrated into the Geographic Information System (GIS) software "QGIS." A field visit was conducted to address remaining issues in the project area. Furthermore, a drainage ditch, two retention basins, and two stormwater collection networks were designed to ensure hydraulic functionality up to the centennial occurrence.

## Keywords :

Hydraulic studies ; Sizing ; Design criteria ; Rainwater ; Soil sealing ; Stormwater collection network ; retention basins ; drainage ditch ; Water Law Declaration File ; QGIS ; Watershed ; Joint Development Zone



*Watersheds and hydraulic structures of the project area*



*Projected land use for the project area*

**Contact(s) :** [romain.marvy@etu.umontpellier.fr](mailto:romain.marvy@etu.umontpellier.fr)



# Study of the ichthyofauna in lagoon environments

establishing pressure/population links



Lucas  
MORISS

Lucas MORISS *STE*

Academic Supervisor : Catherine Aliaume



## Objective / Motivation :

- Establish a bibliography on the ecology of sedentary fish species most commonly found in these lagoons. - Analyze abundance data for these species (on RStudio software) to study the influence of lagoon and season on the size distribution of individuals. - Highlight links between anthropogenic pressures (agricultural pollution, industrial pollution, etc.) and ichthyofauna health.

## Results :

- Graphical representation of trends in species sizes by year and lagoon. - Both a lagoon effect, a season effect and these two factors cross-effects on almost all of the species studied, and this in a very significant way. - Identification of significant links between agricultural and industrial pollution and the size distribution of three species, whether direct (impact on the health of individuals) or indirect (promotion of certain species less sensitive to human pressures).

## Keywords :

Statistics, population study, lagoon ecology, anthropogenic pressures, correlations.



*Photograph of the lagoon of Thau, Occitania, France.*

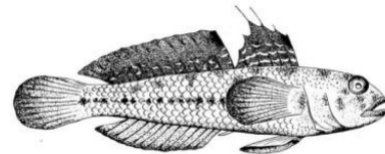

*Black goby.*

Contact(s) : [lucas.moriss@etu.umontpellier.fr](mailto:lucas.moriss@etu.umontpellier.fr)



# diachronic analysis of the downstream Lergue river



**Morgane  
PATUREL**

Study of riverbed evolution

**Morgane PATUREL** *STE*

Academic Supervisor : **Chrystelle Montigny**



## sce

Aménagement  
& environnement

### Objective / Motivation :

A diachronic analysis examines the evolution over time to understand the causes and consequences of changes in the river's course. It focuses on the evolution of the active band (the zone where the alluvial banks have little or no vegetation and are remodeled following an annual or biennial flood). In this case, the diachronic study of the watercourses studied was based on aerial photographs taken in 1954, 1970, 1990, 2005 and 2001, as well as on the Napoleonic cadastre.

### Results :

Changes in the course of a river can manifest themselves in number of ways: widening or narrowing of the bed, creation of new meanders or, on the contrary, a straight course, formation of secondary branches or even a change in the direction of flow. Diachronic data dating back to the Napoleonic cadastre show that the Lergue once had greater lateral mobility, starting at Mas de Mare. Today, the river is only mobile from the confluence with the Ronel, more than a kilometer downstream.

### Keywords :

Evolution, river, diachronic analysis



*Diachronic analysis*

**Contact(s) :** [morgane.paturel@etu.umontpellier.fr](mailto:morgane.paturel@etu.umontpellier.fr)



# Destruction of soil impermeability of an elementary school yard

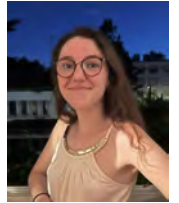

Klerwi  
TORILLEC

Destruction of soil impermeability, an emerging technique for more resilient cities

Klerwi TORILLEC *STE*

Academic Supervisor : Catherine FAUR / Lionel FRERY



## Objective / Motivation :

I was responsible for studying the destruction of soil impermeability of a primary school playground. The aim of the study was to manage run-off and limit heat islands. To achieve this, the depressed green spaces will infiltrate and store run-off water. The first stage of the study involved a site visit. Next, the site was mapped and divided into sub-catchment areas to facilitate run-off management. Finally, for each sub-catchment area, the green spaces were sized by calculating the depth required to accommodate run-off water.

## Results :

The school's site is 50% diswaterproofed. Green spaces, between 15 and 25 cm deep, can handle a return period rain of 20 years or even 30 years, thanks to infiltration and storage.

## Keywords :

Stormwater, Destruction of soil impermeability, Runoff, Resilience



Primary school yard before works



Mapping of the school as a project, showing the division into sub-watersheds

Contact(s) : klerwi.torillec@etu.umontpellier.fr

